

# INSTRUCTION MANUAL

## D1xB2X05, D1xB2X10 & D1xB2X15

### Xenon Beacons with relay / telephone initiation

#### For use in Hazardous Locations

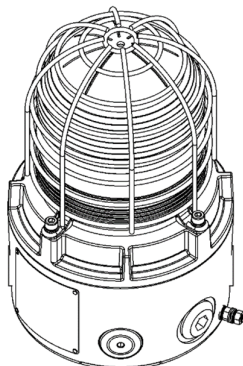

**D1xB2X05-T**  
**D1xB2X10-T**  
**D1xB2X15-T**

## 1) Warnings



- DO NOT OPEN WHEN AN EXPLOSIVE ATMOSPHERE IS PRESENT
- DO NOT OPEN WHEN ENERGISED
- POTENTIAL ELECTROSTATIC CHARGING HAZARD - CLEAN ONLY WITH A DAMP CLOTH
- HIGH VOLTAGE SHOCK HAZARD. WAIT 5 MINUTES AFTER REMOVING POWER BEFORE OPENING THE ENCLOSURE
- DO NOT PAINT
- TO REDUCE THE RISK OF IGNITION OF HAZARDOUS ATMOSPHERES, THE FIRST CONDUIT RUN MUST HAVE A SEALING FITTING CONNECTED WITHIN 18 INCHES OF ENCLOSURE. SUBSEQUENT CONDUIT RUNS MUST HAVE A SEALING FITTING CONNECTED AS CLOSE AS PRACTICAL TO THE WALL OF THE ENCLOSURE, BUT IN NO CASE MORE THAN THE SIZE OF THE CONDUIT OR 50MM, WHICHEVER IS THE LESSER.
- TO PREVENT IGNITION OF GROUP A, B, C AND D ATMOSPHERES - SEE INSTRUCTION FOR CHEMICAL COMPATIBILITY

The D1xB2X05AC115-T & D1xB2X05AC230-T Xenon Beacons are rated as follows:

Ex db IIC T4 Gb Ta -55°C to +70°C  
Ex db IIC T5 Gb Ta -55°C to +50°C  
Ex tb IIIC T116°C Db Ta -55°C to +70°C

The D1xB2X10DC024-T & D1xB2X10DC048-T Xenon Beacons are rated as follows:

Ex db IIC T4 Gb Ta -55°C to +80°C  
Ex db IIC T5 Gb Ta -55°C to +45°C  
Ex tb IIIC T135°C Db Ta -55°C to +80°C

The D1xB2X10AC115-T, D1xB2X10AC230-T, D1xB2X15AC115-T & D1xB2X15AC230-T Xenon Beacons are rated as follows:

Ex db IIC T3 Gb Ta -55°C to +70°C  
Ex db IIC T4 Gb Ta -55°C to +65°C  
Ex tb IIIC T139°C Db Ta -55°C to +70°C

The D1xB2X15DC024-T & D1xB2X15DC048-T Xenon Beacons are rated as follows:

Ex db IIC T3 Gb Ta -55°C to +80°C  
Ex db IIC T4 Gb Ta -55°C to +65°C  
Ex tb IIIC T146°C Db Ta -55°C to +80°C

## 2) Rating & Marking Information

### 2.6 ATEX / IECEx & UKEx Certification

The D1xB2X Xenon beacons comply with the following standards:

EN IEC60079-0:2018 / IEC60079-0:2017 (Ed 7)  
EN60079-1:2014 / IEC60079-1 (Ed. 7) (2014)  
EN60079-31:2014 / IEC60079-31 (Ed. 2) (2013)

The D1xB2X05DC012-T, D1xB2X05DC024-T & D1xB2X05DC048-T Xenon Beacons are rated as follows:

Ex db IIC T4 Gb Ta -55°C to +80°C  
Ex db IIC T5 Gb Ta -55°C to +75°C  
Ex db IIC T6 Gb Ta -55°C to +60°C  
Ex tb IIIC T104°C Db Ta -55°C to +80°C

Certificate No.

DEMKO 19 ATEX 2009X  
IECEX ULD 19.0006X  
UL21UKEX2130X

ATEX Mark,  
Equipment Group and  
Category:



II 2G  
II 2D

CE Marking and  
Notified Body No.



2813

UKCA Marking and  
Notified Body No.



0518

The units can be installed in locations with the following conditions:

## Area Classification:

Zone 1	Explosive gas air mixture likely to occur in normal operation.
Zone 2	Explosive gas air mixture not likely to occur in normal operation, and if it does, it will only exist for a short time.
Zone 21	Explosive dust air mixture likely to occur in normal operation.
Zone 22	Explosive dust air mixture not likely to occur in normal operation, and if it does, it will only exist for a short time.

## Gas Groupings:

Group IIA	Propane
Group IIB	Ethylene
Group IIC	Hydrogen and Acetylene

## Temperature Classification:

T1	450°C	
T2	300°C	
T3	200°C	(D1xB2X15DC-T up to 80°C ambient, D1xB2X10AC-T & D1xB2X15AC up to 70°C ambient,)
T4	135°C	(D1xB2X05DC-T & D1xB2X10DC-T up to 80°C ambient, D1xB2X05AC-T up to 70°C ambient, D1xB2X10AC-T, D1xB2X15DC & D1xB2X15AC-T up to 65°C ambient,
T5	100°C	(D1xB2X05DC-T up to 75°C ambient, D1xB2X05AC-T up to 50°C ambient, D1xB2X10DC-T up to 45°C ambient)
T6	85°C	(D1xB2X05DC-T up to 60°C ambient)

## Dust Groupings:

Group IIIA	Combustible Flyings
Group IIIB	Non-conductive Dust
Group IIIC	Conductive Dust

## Maximum Surface Temperature for Dust Applications:

104°C	(D1xB2X05DC-T)
116°C	(D1xB2X05AC-T)
135°C	(D1xB2X10DC-T)
139°C	(D1xB2X10AC-T, D1xB2X15AC-T)
146°C	(D1xB2X15DC-T)

## Equipment Category: 2G / 2D

## Equipment Protection Level: Gb, Gc, Db, Dc

## Ambient Temperature Range:

-55°C to +80°C	(D1xB2X05DC-T, D1xB2X10DC-T, D1xB2X15DC-T)
-55°C to +70°C	(D1xB2X05AC-T, D1xB2X10AC-T, D1xB2X15AC-T)

## 2.7 Ingress Protection Ratings

The product is rated for ingress Protection as follows:

IP rating per EN60529: IP66

Type rating per UL50E / NEMA250: 4 / 4X / 3R / 13

Suitable for exposure to Acetone, Ammonium Hydroxide, Diethyl Ether, Ethyl Acetate, Ethylene Dichloride, Furfural, n-hexane, Methyl Ethyl Ketone, Methanol, 2-NitroPropane and Toluene.

To maintain the ingress protection rating, the cable entries must be fitted with suitably rated, certified cable entry and/or blanking devices during installation.

## 2.8 Electrical Ratings

Model D1xB2	Nom. Voltage	Voltage Range	Nom. operating current	Max Current
X05DC024-T	24Vdc	20-28Vdc	295	350
X05AC115-T	115Vac	110-120Vac	140	200
X05AC230-T	230Vac	220-240Vac	70	100
X10DC024-T	24Vdc	20-28Vdc	605	710
X10AC115-T	115Vac	110-120Vac	220	300
X10AC230-T	230Vac	220-240Vac	130	180
X15DC024-T	24Vdc	20-28Vdc	835	920
X15AC115-T	115Vac	110-120Vac	310	420
X15AC230-T	230Vac	220-240Vac	170	230

\*Rated at 1Hz

Table 1: Electrical Ratings

It is important that a suitable power supply is used to run the equipment. The power supply selected must have the necessary capacity to provide the input current to all the units.

The input current will vary according to the voltage input level.

## 3) Special Conditions of Use

The enclosure coating is non-conductive and may generate an ignition-capable level of electrostatic charges under certain extreme conditions. The user should ensure that the equipment is not installed in a location where it may be subjected to external conditions (such as high pressure steam) which might cause a build-up of electrostatic charges on non-conducting surfaces. Additionally, cleaning of the equipment should be done only with a damp cloth.

## Flame Path Positions

Flame Path internal thread on base shown hatched

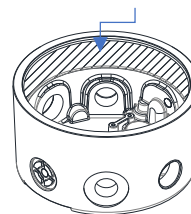

Cemented Joint between glass dome and metal casting on lid shown hatched

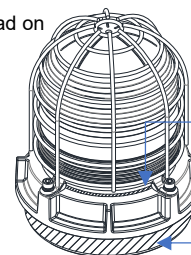

Flame Path external thread on lid shown hatched

## 4) Installation

There are no restrictions on unit orientation.

The unit must only be installed by suitably qualified personnel in accordance with the latest issues of the relevant standards:

EN60079-14 / IEC60079-14: Explosive atmospheres - Electrical installations design, selection and erection

EN60079-10-1 / IEC60079-10-1: Explosive atmospheres - Classification of areas. Explosive gas atmospheres

EN60079-10-2 / IEC60079-10-2: Explosive atmospheres - Classification of areas. Explosive dust atmospheres

The installation of the units must also be in accordance with any local codes that may apply and should only be carried out by a competent electrical engineer who has the necessary training.

### 4.1 Safe Installation Requirements

To maintain the ingress protection rating and mode of protection, the cable entries must be fitted with suitably certified cable entry and/or blanking devices during installation. If conduit is used for installation, seal conduit within 18 inches from the enclosure.

If entries are fitted with adaptors they must be suitably certified for the application. Fitting of blanking elements into adaptors is not permitted.

Check that the 'O' ring seal is in place before replacing the explosionproof cover.

## 5) Location and Mounting

The location of the beacon should be made with due regard to the area over which the warning signal must be visible. It should only be fixed to services that can carry the weight of the unit.

The D1xB2X beacon can be mounted using one of three methods.

1. The beacon can be surface mounted by removing, rotating and reinstalling the stowed mounting lugs. These are suitable for 6mm diameter fixings.

a. Remove 2 x M5 fasteners per mounting lug

b. Reverse and rotate lug and reseal onto enclosure

c. Secure lug using the 2 x M5 Fasteners

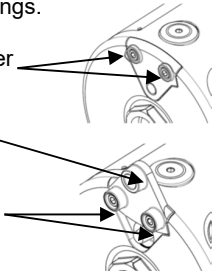

2. Alternatively, the beacon can be conduit mounted using the 3/4" NPT entry on the base of the unit.

3. Additionally, the beacon can be mounted using the ratchet adjustable stainless-steel wall bracket assembly. This is available as an accessory – part code: SP77-0001.

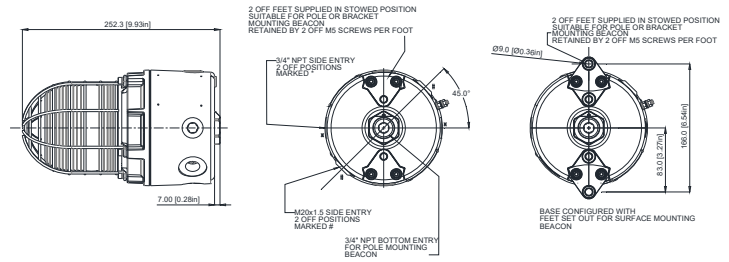

Fig. 1 Fixing Location for Beacon

## 6) Access to the Enclosure



Warning – High voltage may be present, risk of electric shock. DO NOT open when energised, disconnect power before opening.



Warning – Hot surfaces. External surfaces and internal components may be hot after operation, take care when handling the equipment.

In order to connect the electrical supply cables to the beacon, it is necessary to open the explosion proof enclosure. Loosen the locking grub screw in the cover and then remove the glass dome cover assembly to gain access to the chamber. This can be achieved by unscrewing the glass dome cover, taking extreme care not to damage the threads when doing so.

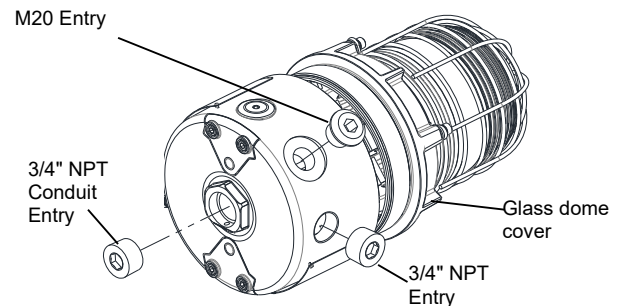

Fig. 2 Accessing the Enclosure.

On completion of the installation the flameproof threads should be inspected to ensure that they are clean and that they have not been damaged during installation. Ensure the O-ring seal is in place and undamaged.

When fitting the flameproof cover ensure the thread is engaged correctly. Fully tighten the cover all the way, ensure no gap is visible between the cover and base of the beacon enclosure.

## 7) Selection of Cable, Cable Glands, Blanking Elements & Adapters

When selecting the cable size, consideration must be given to the input current that each unit draws (see section 11), the number of beacons on the line and the length of the cable runs. The cable size selected must have the necessary capacity to provide the input current to all of the beacons connected to the line.

The entries are 2-off M20 x 1.5 thread & 3-off 3/4" NPT thread

If a high IP (Ingress Protection) rating is required then a suitable sealing washer must be fitted under the cable glands or blanking plugs.

For use in explosive dust atmospheres, a minimum ingress protection rating of IP6X must be maintained.

For use in explosive gas atmospheres, a minimum ingress protection rating of IP54 must be maintained. NPT plugs should be greased before insertion.

For high ambient temperatures the cable entry temperature or the cable branching point temperature may exceed 60°C and therefore suitable heat resisting cables and cable glands must be used, with a rated service temperature of at least the values stated below:

Model D1xB2	Max Ambient Temperature (°C)																		
	-5	0	5	10	15	20	25	30	35	40	45	50	55	60	65	70	75	80	
X05DC												61	66	71	76	81	86	91	96
X05AC							62	67	72	77	82	87	92	97	102	107	-	-	
X10DC							63	68	73	78	83	88	93	98	103	108	113	118	
X10AC					63	68	73	78	83	88	93	98	103	108	113	118	-	-	
X15DC						64	69	74	79	84	89	94	99	104	109	114	119	124	
X15AC	61	66	71	76	81	86	91	96	101	106	111	116	121	126	131	136	-	-	

Table 2: Required Cable/Cable Gland Ratings (°C).

## 8) Cable Connections

The units have 2-off M20 x 1.5 threaded entries and 3-off 3/4" NPT x 14 threaded entries.

Electrical Connections are to be made into the terminal blocks using solid or stranded wire, sizes 0.5-2.5mm<sup>2</sup> / AWG 20-14. Wire insulation needs to be stripped 6-7mm. Wires may be fitted securely with crimped ferrules. Terminal screws need to be tightened down with a tightening torque of 0.4 Nm / 3.5 Lb-in.

See section 6 of this manual for access to the enclosure.

## 9) Earthing

The unit has an external and an internal earth terminal, (please see fig 6).

Please note that for AC supply voltage product versions the Earth terminal on the PCBA does not provide an earth connection to the product enclosure. The enclosure must be independently earthed using either the external or internal earth fixing point, (see fig 6 and notes below).

Internal earthing connections should be made to the internal Earth terminal in the base of the housing using a ring crimped terminal to secure the earth conductor under the earth clamp. The earth conductor should be at least equal in size and rating to the incoming power conductors.

External earthing connections should be made to the M5 earth stud, using a ring crimp terminal to secure the earth conductor to the earth stud. The external earth conductor should be at least 4mm<sup>2</sup> in size.

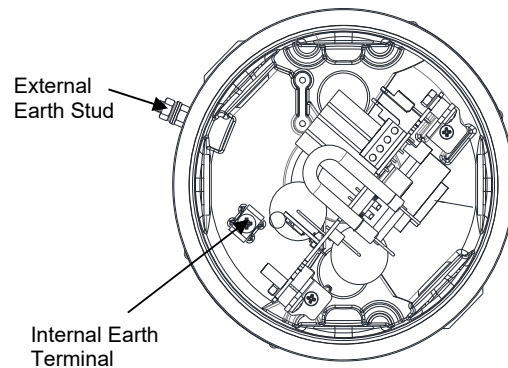

Fig. 6: Internal and External Earth Locations

## 10) Settings

### 10.1 Flash Rate Setting



Warning – high-intensity light source. Avoid looking directly at the light source for extended periods of time.

The D1xB2X beacon can produce different flash patterns as shown in Table 1. The flash patterns are selected by operation of the flash setting DIP switch on the PCB, Fig 7.

Note: Only 1Hz flash rate is Private Mode Fire approved

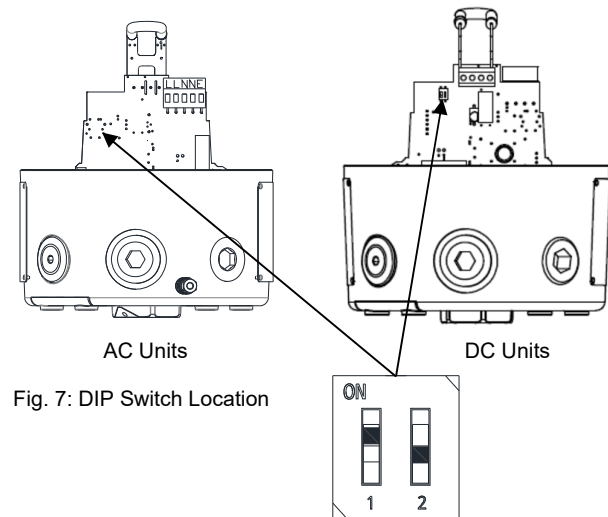

Fig. 7: DIP Switch Location

Switch Setting	S1 Mode
00	1Hz* (60FPM)
01	1.33Hz (80FPM)
10	1.5Hz (90FPM)
11	Double Flash

1=ON; 0=OFF

Example shown (Fig.7):  
10 = Flashing 1.5Hz

(Default setting is 00 1Hz)

Table 3: Switch Positions for Flash Patterns

# 11) Relay / Telephone Inputs and Settings

## 11.1 Power Input Terminal for AC & DC Wiring

A suitable power supply (DC or AC voltage) cable should enter via one of the M20 entries and is to be connected to terminal TB1 (see Fig. 5 below). This provides the beacon with continuous power.

DC Unit option: Connect the beacon power input (+) to the (L/+) terminal (TB1) and power input (-) to the (N/-) at terminal (TB1).

AC Unit option: Connect the beacon input (L) to the (L/+) terminal (TB1) and power input (N) to (N/-) also an earth/ground input to the (E) terminal (TB1). Please note: the earth/ground terminal of TB1 provides termination only for an earth/ground cable. Refer to section 9.

For AC and DC voltage wiring diagrams see document D250-06-001

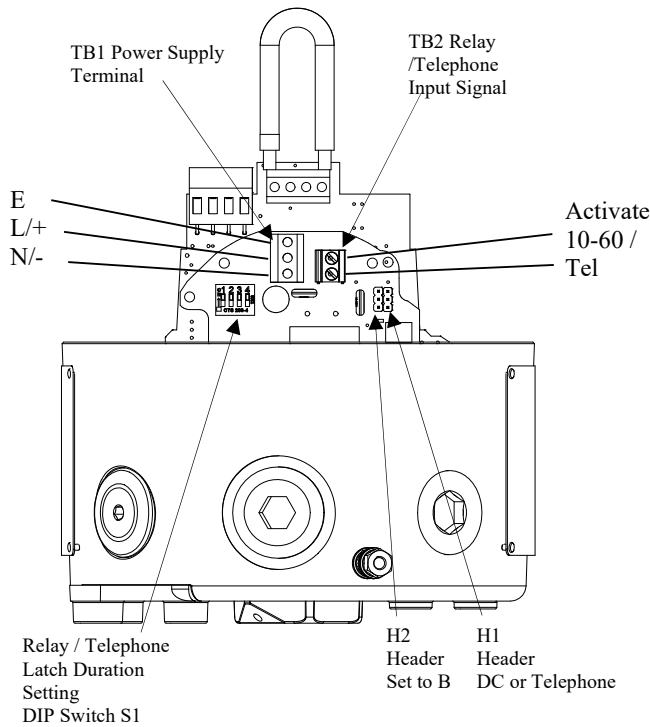

Fig 7 : Input Wiring, DIP settings and Header Positions

## 11.2 Activation, Relay / Telephone Wiring Inputs and Signal Type Header Setting (H1)

The H1 header selection configures the activation signal type.

Select H1 position marked AC for activation from an analogue telephone external ringer output REN1 (typically low current AC voltage around 90 to 150Vac)

Select H1 position marked DC for activation via a DC voltage input of 10 to 60Vdc e.g. a digital PBX external ringer output or a safety system relay output.

The activation input cables should utilise the second M20 cable entry and connect to terminal TB2.

Note: there is no polarity for this input. Factory default H1 is set as AC for activation signal.

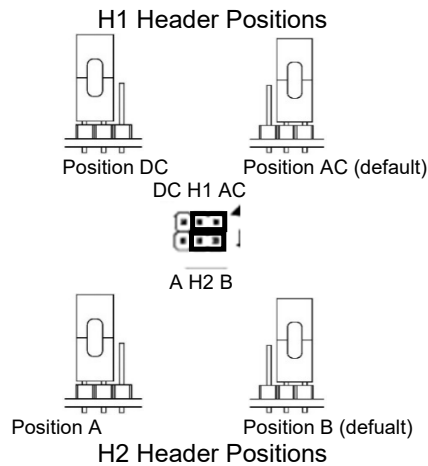

Fig 8: Header H1 and H2 Positions

## 11.3 Unit Activation Mode - Pulsed or Latched, Header Setting (H2)

The H2 header selection configures the beacon operation depending upon the type of activation signal.

Option B is the factory default setting. The beacon visual output will start when an initiation signal is received and will not follow the telephone ringing cadence. See section 9.4

If the unit is set to Option A the beacon will not work effectively.

## 11.4 Unit Latch mode duration DIP switch S1 setting

The relay/telephone latch duration setting is only applicable when Header H2 is set to latched mode via header pin set to position option B.

The beacon is activated on the first telephone ring (or relay pulsed input) and any other subsequent inputs and will remain activated for the duration as set by DIP switch S1.

This feature is useful where some countries have short ringing cadence with long off cycle times and the customer requires the beacon to operate for longer periods to better attract attention.

Where this feature becomes essential is for telephone/relay activated beacons to function correctly in these parameters.

Factory default for the relay/telephone latch duration switch setting is 0000.

See table for DIP switch S1 delay timing.

Unit activation period (s) from start of activation signal.	DIP Switch S1 Setting (0000) = All off
1.5	0000
2.0	1000
2.5	0100
3.0	1100
3.5	0010
4.0	1010
4.5	0110
5.0	1110
5.5	1111

## 12) Interchangeable & Spare Parts



Warning – Hot surfaces. External surfaces and internal components may be hot after operation, take care when handling the equipment.

The Beacon lens cover is interchangeable, contact E2S Ltd for a replacement lens cover available in various colours.

To change the lens cover, unscrew the 4-off M5 socket head screws, spring and flat washers using a 4mm Hex key. Remove the wire guard and replace the old lens cover with the new lens cover.

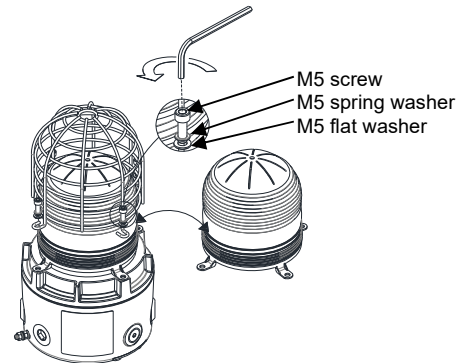

Fig. 8 Replacement of beacon lens cover

Fit the wire guard back onto the housing, over the new lens cover aligning the fixing holes of the guard, lens cover and housing. Refit the fixings to hold into place, the fixings MUST be fitted in the order shown above.

## 13) Maintenance, Overhaul & Repair

Maintenance, repair and overhaul of the equipment should only be carried out by suitably qualified personnel in accordance with the current relevant standards:

EN60079-19 / IEC60079-19 Explosive atmospheres - Equipment repair, overhaul and reclamation

EN 60079-17 / IEC60079-17 Explosive atmospheres - Electrical installations inspection and maintenance

To avoid a possible ELECTROSTATIC CHARGE the unit must only be cleaned with a damp cloth.

Units must not be opened while an explosive atmosphere is present.

If opening the unit during maintenance operations a clean environment must be maintained and any dust layer removed.

Flameproof joints are not intended to be repaired.

1	2	3	4	5	6	7	8	9	10
							ISSUE	MOD No.	REASON - INITIAL - DATE
							A		INTRODUCTION RNP 31/03/2023

**DC Power Input Configuration**      Config.: 1

Used to Activate DC Sounder or Beacon Units  
With Telephone or Relay Signal

Maintain DC Power to TB1  
Stage 1 only : Apply Signal to TB2 Singal Input Terminals

**AC Power Input Configuration**      Config.: 2

Used to Activate AC Sounder or Beacon Units  
With Telephone or Relay Signal

Maintain AC Power to TB1  
Stage 1 only : Apply Signal to TB2 Singal Input Terminals

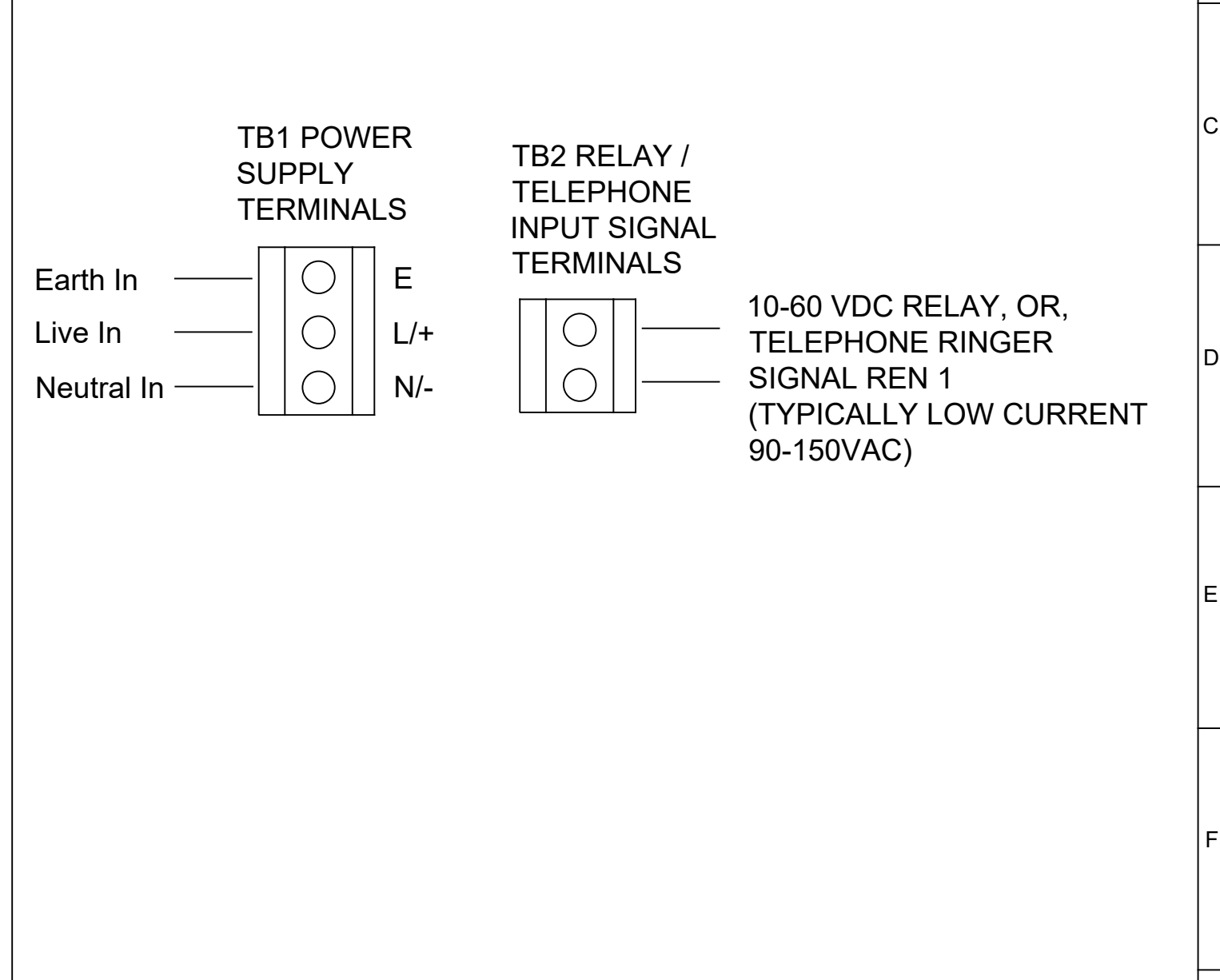
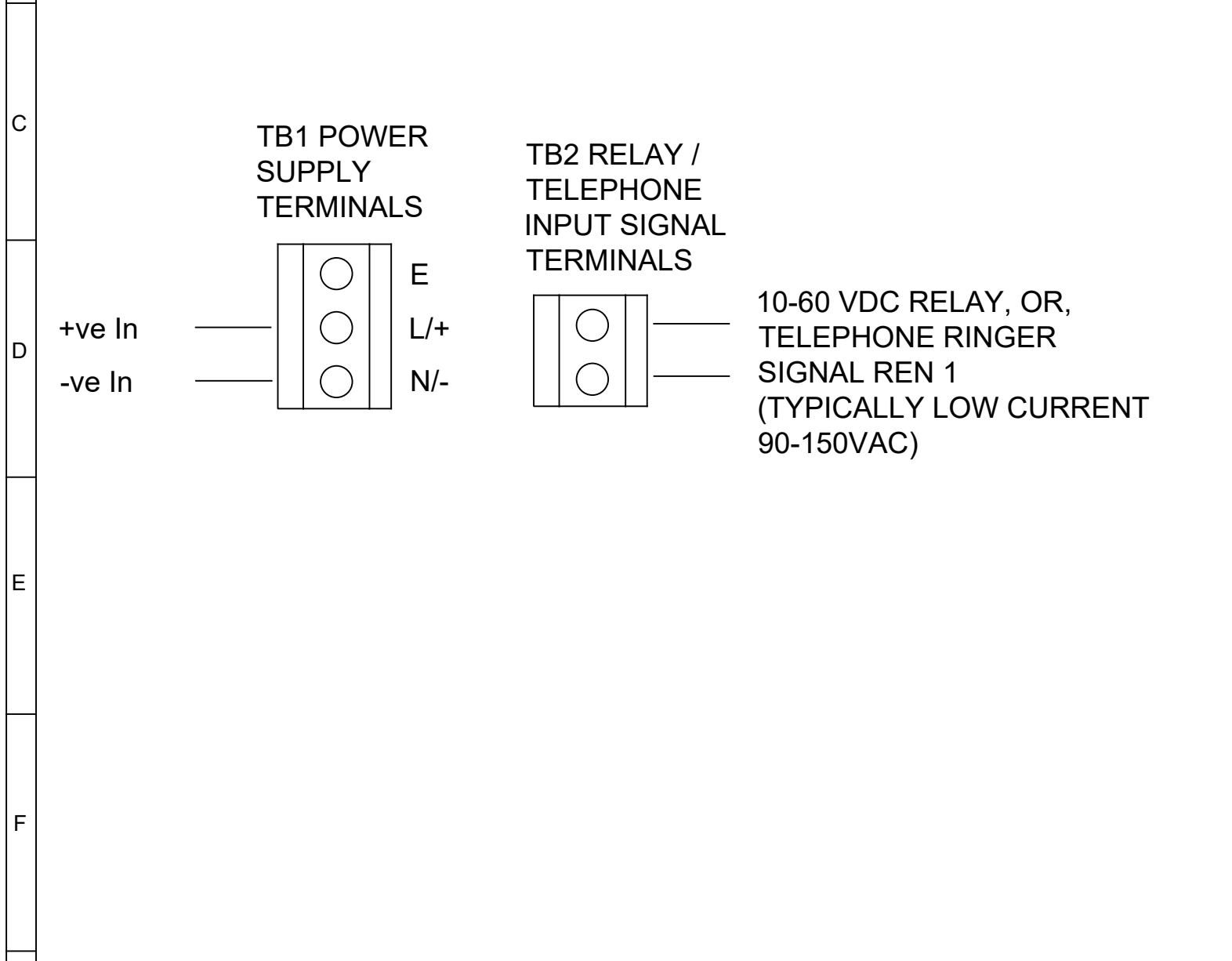

DRAWING TO BS8888:2000 GEOMETRIC TOLERANCES TO ISO1101:1983 LINEAR DIMENSIONAL TOLS ANGULAR DIMENSIONAL TOLS	DRAWN	DATE	SURFACE FINISH	WEIGHT (Kg)	THIS DRAWING AND ANY INFORMATION OR DESCRIPTIVE MATTER THEREIN IS COMMUNICATED IN CONFIDENCE AND IS THE COPYRIGHT PROPERTY OF EUROPEAN SAFETY SYSTEMS LTD. NEITHER THE WHOLE OR ANY EXTRACT MAY BE DISCLOSED, LOANED, COPIED OR USED FOR MANUFACTURING OR TENDERING PURPOSES WITHOUT THEIR WRITTEN CONSENT.	 EUROPEAN SAFETY SYSTEMS LTD IMPRESS HOUSE MANSELL ROAD ACTON LONDON W3 7QH WWW.E2S.COM	ALL DIMENSIONS IN MM			A3
	R.N.POTTS	16/03/2023					MATERIAL			
	CHECKED	DATE	ALTERNATIVE MATERIAL				TITLE TELEPHONE / RELAY ACTIVATION MODULE WIRING DIAGRAMS			
	R.S.RAIT	16/03/2023					SCALE	SHEET	DRAWING NUMBER	
STANDARDS	APPROVED	DATE			NTS	1 OF 1	D250-06-001			
ALERTALARM RANGE	R.N.POTTS	16/03/2023								

# EU Declaration of Conformity



Manufacturer: European Safety Systems Ltd.  
Impress House, Mansell Road, Acton  
London, W3 7QH  
United Kingdom

Authorised Representative: E2S Warnsignaltechnik UG  
Charlottenstrasse 45-51  
72764 Reutlingen  
Germany

Equipment Type: D1xB2X05, D1xB2X10, D1xB2X15, D1xB2X21, D1xB2LD2, D1xJ2

---

## Directive 2014/34/EU: Equipment and Protective Systems for use in Potentially Explosive Atmospheres (ATEX)

Notified Body for EU type Examination (Module B):	UL International Demko A/S Notified Body No.: 0539 Borupvang 5A, 2750 Ballerup, Denmark
EU-type Examination Certificate (Module B):	DEMKO 19 ATEX 2009X Rev. 1
Notified Body for Quality Assurance Notification / Conformity to EU-type based on quality assurance of the production process (Module D):	Sira Certification Service Notified Body No.: 2813 CSA Group Netherlands B.V, Utrechtseweg 310, 6812 AR, Arnhem, Netherlands
Quality Assurance Notification (Module D):	SIRA 05 ATEX M342
Provisions fulfilled by the equipment:	II 2G Ex d IIC T6...T3 Gb II 2D Ex tb IIIC T95°C...T169°C Db
Standards applied:	EN 60079-0:2018 EN 60079-1:2014 EN 60079-31:2014 IP6X Dust Protection to EN60079-0 / EN60079-31

## Regulation EU No. 305/2011: Construction Products Regulation (CPR) –part codes listed below only – 1Hz Flash Mode only

Notified Product Certification Body for Certificate of Constancy of Performance or EC Type Examination Certificate and continuous surveillance, assessment and evaluation of factory production control:	BRE Global Assurance (Ireland) Limited Notified Body No.: 2831 DCU Alpha, Old Finglas Road, Glasnevin, Dublin, D11 KXN4
Certificate of Constancy of Performance or EC Type Examination Certificate:	2831-CPR-F4859 (D1xB2X05DC024***A1R/C, D1xB2X05DC024***A1G/C only) 2831-CPR-F4899 (D1xB2X05DC024***A1R/R, D1xB2X05DC024***A1G/R only)
Standards applied:	EN 54-23:2010

## Directive 2014/90/EU: Marine Equipment Directive (MED) – part codes specified only – D1xB2X05DC024\*\*\*A1R/C ; D1xB2X05DC024\*\*\*A1R/R ; D1xB2X05DC024\*\*\*A1G/C ; D1xB2X05DC024\*\*\*A1G/R

Notified Body for EU type Examination (Module B) and Conformity to EU-type based on quality assurance of the production process (Module D):	DNV AS Notified Body No.: 0575 DNV Høvik, Norway
EU-Certificate Type Examination (Module B):	MEDB000085K
EU Certificate of Conformity for the Quality Assurance System (Module D):	MEDD00000GV
Standards applied:	EN 54-3:2014 incl. A1: 2019 EN 54-23:2010 IEC 60092-504: 2016

# EU Declaration of Conformity



IEC 60533: 2015

## Directive 2014/30/EU: Electromagnetic Compatibility Directive (EMC)

Standards applied:

EN IEC 61000-6-1:2019 & IEC 61000-6-1:2016  
EN IEC 61000-6-2:2019 & IEC 61000-6-2:2016  
EN IEC 61000-6-3:2021 & IEC 61000-6-3:2020  
EN IEC 61000-6-4:2019 & IEC 61000-6-4:2018

## Directive 2011/65/EU: Restriction of the use of certain hazardous substances in electrical and electronic equipment (RoHS)

The product and all the components contained within it are in accordance with the restriction of the use of hazardous substances in electrical and electronic equipment, including amendment by Directive 2015/863/EU.

## Regulation (EC) 1907/2006: Registration, Evaluation, Authorisation and Restriction of Chemicals (REACH)

The product and all the components contained within it are free from substances of very high concern.

## Other Standards and Regulations

EN 60529:1991 + A1:2000 + A2:2013. - Degrees of protection provided by enclosures (IP code) – enclosure rated IP66/67

---

On behalf of European Safety Systems Ltd., I declare that, on the date the equipment accompanied by this declaration is placed on the market, the equipment conforms with all technical and regulatory requirements of the above listed directives, regulations and standards.

This Declaration is issued under the sole responsibility of the manufacturer.

A blue ink signature of Desmond Gayler, written in a cursive style.

Desmond Gayler  
Quality Assurance Manager

Document No.: DC-077\_Issue\_G  
Date and Place of Issue: London, 01/09/2023



# UKCA Declaration of Conformity



Manufacturer: European Safety Systems Ltd.  
 Impress House, Mansell Road, Acton  
 London, W3 7QH  
 United Kingdom

Equipment Type: D1xB2X05, D1xB2X10, D1xB2X15, D1xB2X21, D1xB2LD2, D1xJ2

Directive UKSI 2016:1107 (as amended by UKSI 2019:696) – Schedule 3A, Part 1 : Product or Protective System Intended for use in Potentially Explosive Atmospheres (UKCA)

Notified Body for UK type Examination (Module B):	UL International (UK) Ltd Notified Body No.: 0843 Unit 1-3 Horizon Kingsland Business Park, Wade Road, Basingstoke, Hampshire RG24 8AH UK
UK-type Examination Certificate (Module B):	UL21UKEX2130X
Notified Body for Quality Assurance Notification / Conformity to EU-type based on quality assurance of the production process (Module D):	Sira Certification Service Notified Body No.: 0518 Rake Lane, Eccleston, Chester CH4 9JN, UK
Quality Assurance Notification (Module D):	CSAE 22UKQAN0046
Provisions fulfilled by the equipment:	II 2G Ex d IIC T6...T3 Gb II 2D Ex tb IIIC T95°C...T169°C Db
Standards applied:	EN 60079-0:2018 EN 60079-1:2014 EN 60079-31:2014 IP6X Dust Protection to EN60079-0 / EN60079-31

Regulation EU No. 305/2011: Construction Products Regulation (CPR) –part codes listed below only – 1Hz Flash Mode only

Notified Product Certification Body for Certificate of Constancy of Performance or EC Type Examination Certificate and continuous surveillance, assessment and evaluation of factory production control:	BRE Global Limited Notified Body No.: 0832 Bucknalls Lane, Garston, Watord, Hertfordshire, UK, WD25 9XX
Certificate of Constancy of Performance or EC Type Examination Certificate:	0832-UKCA-CPR-F41783 (D1xB2X05DC024***A1R/C, D1xB2X05DC024***A1G/C only)  0832-UKCA-CPR-F1854 (D1xB2X05DC024***A1R/R, D1xB2X05DC024***A1G/R only)
Standards applied:	EN 54-23:2010

UK Merchant Shipping, Marine Equipment Regulation (MER) 2016 SI 2016/1025– part codes specified only - D1xB2X05DC024\*\*\*A1R/C, D1xB2X05DC024\*\*\*A1G/C, D1xB2X05DC024\*\*\*A1R/R, D1xB2X05DC024\*\*\*A1G/R

Notified Body for UK type Examination (Module B) and Conformity to UK-type based on quality assurance of the production process (Module D):	DNV UK Notified Body No.: 0097 DNV, UK
UK-Certificate Type Examination (Module B):	MERB000085K
UK Certificate of Conformity for the Quality Assurance System (Module D):	MERD00000GV
Standards applied:	EN 54-3:2014 incl. A1: 2019 EN 54-23:2010 IEC 60092-504: 2016 IEC 60533: 2015



# UKCA Declaration of Conformity



## Directive 2014/30/EU: Electromagnetic Compatibility Directive (EMC)

Standards applied:

EN 61000-6-1:2007  
EN 61000-6-2:2005  
EN 61000-6-3:2007 / A1:2011 / AC: 2012  
EN 61000-6-4:2007 / A1: 2011

## Directive 2011/65/EU: Restriction of the use of certain hazardous substances in electrical and electronic equipment (RoHS)

The product and all the components contained within it are in accordance with the restriction of the use of hazardous substances in electrical and electronic equipment, including amendment by Directive 2015/863/EU.

## Regulation (EC) 1907/2006: Registration, Evaluation, Authorisation and Restriction of Chemicals (REACH)

The product and all the components contained within it are free from substances of very high concern.

## Other Standards and Regulations

EN 60529:1991 + A1:2000 + A2:2013. - Degrees of protection provided by enclosures (IP code) – enclosure rated IP66/67

---

On behalf of European Safety Systems Ltd., I declare that, on the date the equipment accompanied by this declaration is placed on the market, the equipment conforms with all technical and regulatory requirements of the above listed directives, regulations and standards.

This Declaration is issued under the sole responsibility of the manufacturer.

Desmond Gayler  
Quality Assurance Manager

Document No.: DC-096\_Issue\_C  
Date and Place of Issue: London, 18/03/2024