

# INSTRUCTION MANUAL

**D1xB2X05-S, D1xB2X10-S, D1xB2X15-S**

**Xenon Beacons – SIL2**

**For use in Hazardous Locations**

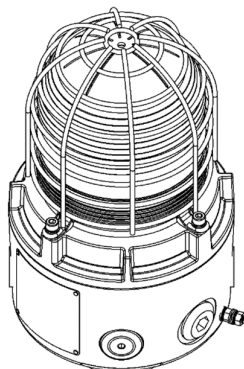

**D1xB2X05-S  
D1xB2X10-S  
D1xB2X15-S**

## 1) Warnings



- DO NOT OPEN WHEN AN EXPLOSIVE ATMOSPHERE IS PRESENT
- DO NOT OPEN WHEN ENERGISED
- POTENTIAL ELECTROSTATIC CHARGING HAZARD - CLEAN ONLY WITH A DAMP CLOTH
- HIGH VOLTAGE SHOCK HAZARD. WAIT 5 MINUTES AFTER REMOVING POWER BEFORE OPENING THE ENCLOSURE
- DO NOT PAINT
- TO REDUCE THE RISK OF IGNITION OF HAZARDOUS ATMOSPHERES, THE FIRST CONDUIT RUN MUST HAVE A SEALING FITTING CONNECTED WITHIN 18 INCHES OF ENCLOSE. SUBSEQUENT CONDUIT RUNS MUST HAVE A SEALING FITTING CONNECTED AS CLOSE AS PRACTICAL TO THE WALL OF THE ENCLOSURE, BUT IN NO CASE MORE THAN THE SIZE OF THE CONDUIT OR 50MM, WHICHEVER IS THE LESSER.
- TO PREVENT IGNITION OF GROUP A, B, C AND D ATMOSPHERES - SEE INSTRUCTION FOR CHEMICAL COMPATIBILITY

### Avertissement:

- NE PAS OUVRIR UN PRESENCE D'ATMOSPHERE EXPLOSIVE
- NE PAS OUVRIR ENERGIE
- DANGER POTENTIEL CHARGE ÉLECTROSTATIQUE - NETTOYER UNIQUEMENT AVEC UN CHIFFON HUMIDE
- HAUT TENSION, RISK DE CHOC. ATTENDEZ 5 MINUTES APRES AVOIR DEBRANCHE L'ALIMENTATION AVANT D'OUVRIR LA BOITIER
- NE PAS PEINTURER
- POUR RÉDUIRE LE RISQUE D'INFLAMMATION DES ATMOSPHERES DANGEREUSES, LE PREMIER CONDUIT DE CONDUIT DOIVENT AVOIR UN RACCORD D'ÉTANCHÉITÉ RACCORDÉ À MOINS DE 18

POUCES DE L'ENFERMEMENT. POUR SUBSÉQUENT LES CONDUITES DE CONDUIT LA DISTANCE ENTRE LA SURFACE DE LA MASSE DE REMPLISSAGE AU PLUS PRÈS DE L'ENVELOPPE DOIT ÊTRE AUSSI PETITE QUE CE QUI EST RÉALISABLE MAIS EN AUCUN CAS SUPÉRIEURE À LA PLUS PETITE DES DIMENSIONS CORRESPONDANT À LA TAILLE DU CONDUIT OU À 50 MM.

- POUR PRÉVENIR L'INFLAMMATION DES ATMOSPHERES DES GROUPES A, B, C ET D-VOIR L'INSTRUCTION POUR LA COMPATIBILITÉ CHIMIQUE

## 2) Rating & Marking Information

### 2.1 Fire Alarm Ratings

The Following models are certified as visual alarm devices for fire alarm use – private mode only when used with Clear or Red lens covers:

D1xB2X05DC024 / D1xB2X10DC024 / D1xB2X15DC024

On-axis light output per UL 1638:

Model D1xB2	Light Intensity in cd	
	Clear Lens	Red Lens
X05DC024-S - 1Hz	20.44	5.89
X05DC024-S - 1.33Hz	14.47	4.17
X05DC024-S - 1.5Hz	11.1	2.13
X10DC024-S - 1Hz	69.81	23.66
X10DC024-S - 1.33Hz	49.42	16.75
X10DC024-S - 1.5Hz	35.71	8.57
X15DC024-S - 1Hz	98.61	31.83
X15DC024-S - 1.33Hz	69.81	22.53
X15DC024-S - 1.5Hz	50.44	11.53

## 2.2 surge current ratings for use in fire alarm systems

Model D1xB2	Nominal Voltage	Voltage Range	Flash Rate	Peak Surge current	RMS surge current
X05DC024-S	24Vdc	20-28Vdc	1Hz	955mA	370mA
			1.33Hz	960mA	370mA
			1.5Hz	955mA	365mA
			Double	960mA	355mA
X10DC024-S	24Vdc	20-28Vdc	1Hz	970mA	700mA
			1.33Hz	970mA	700mA
			1.5Hz	990mA	700mA
			Double	990mA	695mA
X15DC024-S	24Vdc	20-28Vdc	1Hz	990mA	925mA
			1.33Hz	990mA	930mA
			1.5Hz	990mA	925mA
			Double	990mA	905mA

## 2.3 NEC & CEC Class / Division Ratings for US / Canada

The D1xB2X Xenon beacons comply with the following standards:

UL 1203 (Ed. 5) 2020  
 UL1638A (Ed. 1) 2016  
 UL1638 (Ed. 5) 2017  
 CSA C22.2 No. 30 (Ed. 4) 2020  
 CSA C22.2 No. 25 (Ed. 4) 2017  
 CSA C22.2 No. 205 (Ed. 3) 2017

The D1xB2X05DC024 Xenon Beacons are rated as follows:

Class I Div 1 Group ABCD T5 Ta -55°C to +80°C  
 Class I Div 1 Group ABCD T6 Ta -55°C to +65°C  
 Class II Div 1 Group EFG T5 Ta -55°C to +80°C  
 Class III Div 1 Ta -55°C to +80°C

The D1xB2X10DC024 Xenon Beacons are rated as follows:

Class I Div 1 Group ABCD T4 Ta -55°C to +80°C  
 Class I Div 1 Group ABCD T4A Ta -55°C to +70°C  
 Class I Div 1 Group ABCD T5 Ta -55°C to +50°C  
 Class II Div 1 Group EFG T4 Ta -55°C to +80°C  
 Class III Div 1 Ta -55°C to +80°C

The D1xB2X15DC024 Xenon Beacons are rated as follows:

Class I Div 1 Group ABCD T3C Ta -55°C to +80°C  
 Class I Div 1 Group ABCD T4 Ta -55°C to +55°C  
 Class II Div 1 Group EFG T4 Ta -55°C to +80°C  
 Class III Div 1 Ta -55°C to +80°C

Installation must be carried out in compliance with the National Electric Code / Canadian Electric Code

## 2.4 NEC Class / Zone ratings US

The D1xB2X Xenon beacons comply with the following standards:

UL 60079-0 (Ed. 7) 2020  
 UL 60079-1 (Ed. 7) 2020  
 UL 60079-31 (Ed. 2) 2020

The D1xB2X05DC024 Xenon Beacons are rated as follows:

Class I Zone 1 AEx db IIC T4 Ta -55°C to +80°C  
 Class I Zone 1 AEx db IIC T5 Ta -55°C to +75°C  
 Class I Zone 1 AEx db IIC T6 Ta -55°C to +60°C  
 Zone 21 AEx tb IIIC T99°C Ta -55°C to +80°C

The D1xB2X10DC024 Xenon Beacons are rated as follows:

Class I Zone 1 AEx db IIC T4 Ta -55°C to +80°C  
 Class I Zone 1 AEx db IIC T5 Ta -55°C to +45°C  
 Zone 21 AEx tb IIIC T132°C Ta -55°C to +80°C

The D1xB2X15DC024 Xenon Beacons are rated as follows:

Class I Zone 1 AEx db IIC T3 Ta -55°C to +80°C  
 Class I Zone 1 AEx db IIC T4 Ta -55°C to +65°C  
 Zone 21 AEx tb IIIC T132°C Ta -55°C to +80°C

Installation must be carried out in compliance with the National Electric Code.

## 2.5 CEC Class / Zone ratings Canada

The D1xB2X Xenon beacons comply with the following standards:

CAN/CSA C22.2 No. 60079-0 (Ed. 4) 2019  
 CAN/CSA C22.2 No. 60079-1 (Ed. 3) 2016  
 CAN/CSA C22.2 No. 60079-31 (Ed. 2) 2015

The D1xB2X05DC024 Xenon Beacons are rated as follows:

Ex db IIC T4 Ta -55°C to +80°C  
 Ex db IIC T5 Ta -55°C to +75°C  
 Ex db IIC T6 Ta -55°C to +60°C  
 Ex tb IIIC T99°C Ta -55°C to +80°C

The D1xB2X10DC024 Xenon Beacons are rated as follows:

Ex db IIC T4 Ta -55°C to +80°C  
 Ex db IIC T5 Ta -55°C to +45°C  
 Ex tb IIIC T132°C Ta -55°C to +80°C

The D1xB2X15DC024 Xenon Beacons are rated as follows:

Ex db IIC T3 Ta -55°C to +80°C  
 Ex db IIC T4 Ta -55°C to +65°C  
 Ex tb IIIC T132°C Ta -55°C to +80°C

Installation must be carried out in compliance with the Canadian Electric Code

## 2.6 ATEX / IECEx & UKEx Certification

The D1xB2X Xenon beacons comply with the following standards:

EN IEC60079-0:2018 / IEC60079-0:2017 (Ed 7)  
 EN60079-1:2014 / IEC60079-1 (Ed. 7) (2014)  
 EN60079-31:2014 / IEC60079-31 (Ed. 2) (2013)

The D1xB2X05DC024 Xenon Beacons are rated as follows:

Ex db IIC T4 Gb Ta -55°C to +80°C  
 Ex db IIC T5 Gb Ta -55°C to +75°C  
 Ex db IIC T6 Gb Ta -55°C to +60°C  
 Ex tb IIIC T104°C Db Ta -55°C to +80°C

The D1xB2X10DC024 Xenon Beacons are rated as follows:

Ex db IIC T4 Gb Ta -55°C to +80°C  
 Ex db IIC T5 Gb Ta -55°C to +45°C  
 Ex tb IIIC T135°C Db Ta -55°C to +80°C

The D1xB2X15DC024 Xenon Beacons are rated as follows:

Ex db IIC T3 Gb Ta -55°C to +80°C  
 Ex db IIC T4 Gb Ta -55°C to +65°C  
 Ex tb IIIC T146°C Db Ta -55°C to +80°C

**Certificate No.** DEMKO 19 ATEX 2009X  
 IECEx ULD 19.0006X  
 UL21UKEX2130X

**ATEX Mark, Equipment Group and Category:**  II 2G  
 II 2D

**CE Marking and Notified Body No.**  2813

**UKCA Marking and Notified Body No.**  0518

The units can be installed in locations with the following conditions:

### Area Classification:

Zone 1	Explosive gas air mixture likely to occur in normal operation.
Zone 2	Explosive gas air mixture not likely to occur in normal operation, and if it does, it will only exist for a short time.
Zone 21	Explosive dust air mixture likely to occur in normal operation.
Zone 22	Explosive dust air mixture not likely to occur in normal operation, and if it does, it will only exist for a short time.

### Gas Groupings:

Group IIA	Propane
Group IIB	Ethylene
Group IIC	Hydrogen and Acetylene

### Temperature Classification:

T1	450°C	
T2	300°C	
T3	200°C	(D1xB2X15DC up to 80°C ambient,)
T4	135°C	(D1xB2X05DC & D1xB2X10DC up to 80°C ambient, D1xB2X15DC up to 65°C ambient)
T5	100°C	(D1xB2X05DC up to 75°C ambient, D1xB2X10DC up to 45°C ambient)
T6	85°C	(D1xB2X05DC up to 60°C ambient)

### Dust Groupings:

Group IIIA	Combustible Flyings
Group IIIB	Non-conductive Dust
Group IIIC	Conductive Dust

### Maximum Surface Temperature for Dust Applications:

104°C (D1xB2X05DC)  
 135°C (D1xB2X10DC)  
 146°C (D1xB2X15DC)

**Equipment Category:** 2G / 2D

**Equipment Protection Level:** Gb, Gc, Db, Dc

### Ambient Temperature Range:

-55°C to +80°C (D1xB2X05DC, D1xB2X10DC, D1xB2X15DC)

The certification approval has validated continuous use up to 38°C ambient and also for transient use up to 80°C ambient. The test standards UL1638 and UL1638A require approved devices to operate continuously in an ambient of 25°C. The E2S range of D1xB2 strobe beacons comply with this test. Additionally, the D1xB2 range have been tested at an elevated temperatures continuously in ambient temperatures of 38°C. Continuous use is defined as a state of in which the device is powered permanently, at all times, without any off period. Transient use is defined as a state in which the device is activated by the safety system and remains powered whilst the alarm condition exists. The D1xB2 range has been UL approved for use in environments from -55°C to +80°C.

## 2.7 Ingress Protection Ratings

The product is rated for ingress Protection as follows:

IP rating per EN60529: IP66  
 Type rating per UL50E / NEMA250: 4 / 4X / 3R / 13

Suitable for exposure to Acetone , Ammonium Hydroxide , Diethyl Ether , Ethyl Acetate , Ethylene Dichloride , Furfural , n-hexane , Methyl Ethyl Ketone , Methanol , 2-NitroPropane and Toluene.

To maintain the ingress protection rating, the cable entries must be fitted with suitably rated, certified cable entry and/or blanking devices during installation.

## 2.8 Electrical Ratings

Model D1xB2	Nom. Voltage	Voltage Range	Nom. operating current	Max Current
X05DC024-S	24Vdc	20-28Vdc	295	350
X10DC024-S	24Vdc	20-28Vdc	605	710
X15DC024-S	24Vdc	20-28Vdc	835	920

\*Rated at 1Hz

Table 1: Electrical Ratings

It is important that a suitable power supply is used to run the equipment. The power supply selected must have the necessary capacity to provide the input current to all the units.

The input current will vary according to the voltage input level.

### 3) Special Conditions of Use

The enclosure coating is non-conductive and may generate an ignition-capable level of electrostatic charges under certain extreme conditions. The user should ensure that the equipment is not installed in a location where it may be subjected to external conditions (such as high pressure steam) which might cause a build-up of electrostatic charges on non-conducting surfaces. Additionally, cleaning of the equipment should be done only with a damp cloth.

#### Flame Path Positions

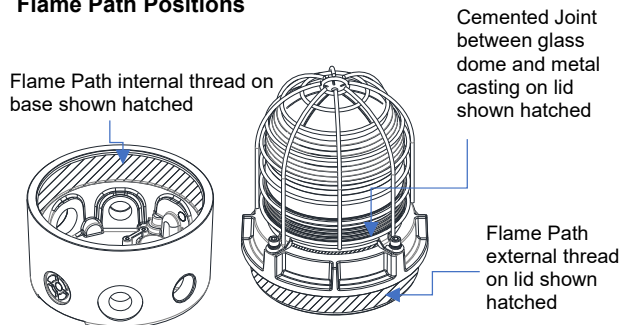

Figure 1: Flame Path.

### 4) Installation

There are no restrictions on unit orientation.

The beacon must only be installed by suitably qualified personnel in accordance with the latest issues of the relevant standards:

EN60079-14 / IEC60079-14: Explosive atmospheres - Electrical installations design, selection and erection

EN60079-10-1 / IEC60079-10-1: Explosive atmospheres - Classification of areas. Explosive gas atmospheres

EN60079-10-2 / IEC60079-10-2: Explosive atmospheres - Classification of areas. Explosive dust atmospheres

The installation of the units must also be in accordance with any local codes that may apply and should only be carried out by a competent electrical engineer who has the necessary training.

## 4.1 Safe Installation Requirements

To maintain the ingress protection rating and mode of protection, the cable entries must be fitted with suitably certified cable entry and/or blanking devices during installation. If conduit is used for installation, seal conduit within 18 inches from the enclosure.

If entries are fitted with adaptors they must be suitably certified for the application. Fitting of blanking elements into adaptors is not permitted.

Check that the 'O' ring seal is in place before replacing the explosionproof cover.

The lens guard is optional. However in Class Division installations when a diffused lens is used, the stainless steel guard becomes mandatory and must be fitted also.

### 5) Location and Mounting

The location of the beacon should be made with due regard to the area over which the warning signal must be visible. It should only be fixed to services that can carry the weight of the unit.

The D1xB2X beacon can be mounted using one of three methods.

- The beacon can be surface mounted by removing, rotating and reinstalling the stowed mounting lugs. These are suitable for 6mm diameter fixings.

- Remove 2 x M5 fasteners per mounting lug
- Reverse and rotate lug and reseat onto enclosure
- Secure lug using the 2 x M5 Fasteners

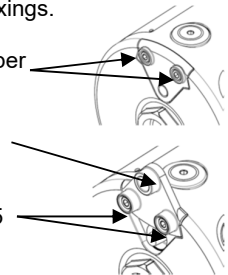

- Alternatively the beacon can be conduit mounted using the 3/4" NPT entry on the base of the unit.

- Additionally, the beacon can be mounted using the ratchet adjustable stainless-steel wall bracket assembly. This is available as an accessory – part code: SP77-0001.

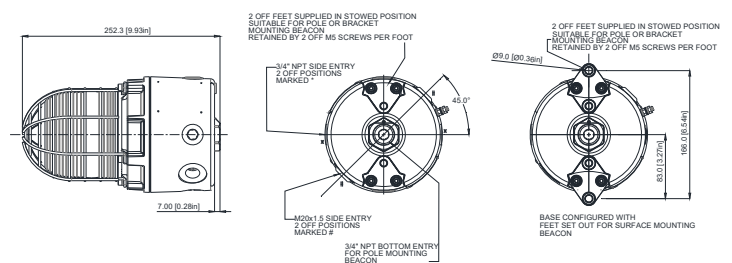

Figure 2: Fixing Location for Beacon.

## 6) Access to the Enclosure



Warning – High voltage may be present, risk of electric shock. DO NOT open when energised, disconnect power before opening.



Warning – Hot surfaces. External surfaces and internal components may be hot after operation, take care when handling the equipment.

In order to connect the electrical supply cables to the beacon, it is necessary to open the explosion proof enclosure. Loosen the locking grub screw in the cover and then remove the glass dome cover assembly to gain access to the chamber. This can be achieved by unscrewing the glass dome cover, taking extreme care not to damage the threads when doing so.

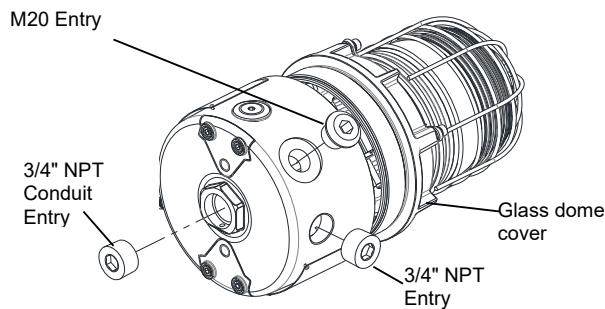

Figure 3: Accessing the Explosion Proof Enclosure.

On completion of the installation the flameproof threads should be inspected to ensure that they are clean and that they have not been damaged during installation. Ensure the O-ring seal is in place and undamaged.

When fitting the flameproof cover ensure the thread is engaged correctly. Fully tighten the cover all the way, ensure no gap is visible between the cover and base of the beacon enclosure.

## 7) Selection of Cable, Cable Glands, Blanking Elements & Adapters

When selecting the cable size, consideration must be given to the input current that each unit draws (see section 11), the number of beacons on the line and the length of the cable runs. The cable size selected must have the necessary capacity to provide the input current to all of the beacons connected to the line.

The entries are 2-off M20 x 1.5 thread & 3-off 3/4" NPT thread

If a high IP (Ingress Protection) rating is required then a suitable sealing washer must be fitted under the cable glands or blanking plugs.

For use in explosive dust atmospheres, a minimum ingress protection rating of IP6X must be maintained.

For use in explosive gas atmospheres, a minimum ingress protection rating of IP54 must be maintained. NPT plugs should be greased before insertion.

For high ambient temperatures the cable entry temperature or the cable branching point temperature may exceed 60°C and therefore suitable heat resisting cables and cable glands must be used, with a rated service temperature of at least the values stated below:

Model D1xB2	Max Ambient Temperature (°C)													
	20	25	30	35	40	45	50	55	60	65	70	75	80	
X05DC-SIL							61	66	71	76	81	86	91	96
X10DC-SIL		63	68	73	78	83	88	93	98	103	108	113	118	
X15DC-SIL	64	69	74	79	84	89	94	99	104	109	114	119	124	

Table 2: Min. Ratings of Cables & Cable Glands.

## 8) Cable Connections

The units have 2-off M20 x 1.5 threaded entries and 3-off 3/4" NPT x 14 threaded entries.

Electrical Connections are to be made into the terminal blocks using solid or stranded wire, sizes 0.5-2.5mm<sup>2</sup> / AWG 20-14. Wire insulation needs to be stripped 6-7mm. Wires may be fitted securely with crimped ferrules. Terminal screws need to be tightened down with a tightening torque of 0.4 Nm / 3.5 Lb-in.

See section 6 of this manual for access to the enclosure.

## 9) Wiring

A 4-way terminal block is provided on the DC beacons for power. There are 2-off +ve, 2-off -ve terminal and an internal Earth boss.

See schematic diagram D191-06-621.

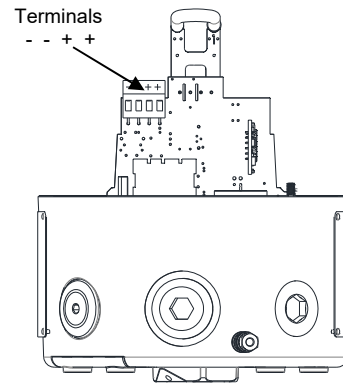

Figure 4: D1xB2XDC Terminals.

### 9.1 Line Monitoring

On the D1xB2X unit, DC reverse line monitoring can be used if required.

All DC beacons have a blocking diode fitted in their supply input lines. An end of line monitoring resistor can be connected across the +ve and -ve terminals in the explosion proof enclosure. If an end of line resistor is used it must have the following values:

Minimum resistance 3K3 Ohms  
Minimum resistance 470 Ohms

Minimum Power 0.5W  
Minimum Power 2.0W

The resistor must be connected directly across the +ve and -ve terminals as shown in the following drawing. Form the resistor legs as shown in Figure 5a, fit the resistor across the two terminals, as shown in Figure 5b.

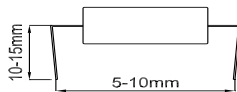

Figure 5a: End of Line Resistor Forming.

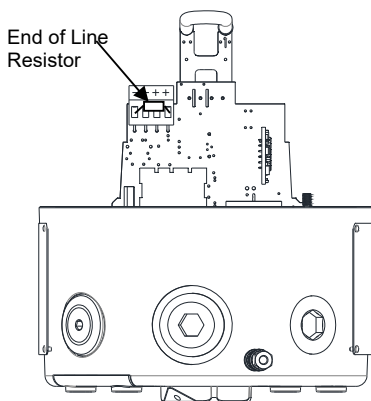

Figure 5b: End of Line Resistor Placement.

SIL2 line monitoring module product version: see section 21 for standard default values and product coding. See document D191-06-621 for associated wiring diagram.

## 10) Earthing

The unit has an external and an internal earth terminal, (please see Figure 6).

Internal earthing connections should be made to the internal Earth terminal in the base of the housing using a ring crimped terminal to secure the earth conductor under the earth clamp. The earth conductor should be at least equal in size and rating to the incoming power conductors.

External earthing connections should be made to the M5 earth stud, using a ring crimp terminal to secure the earth conductor to the earth stud. The external earth conductor should be at least 4mm in size.

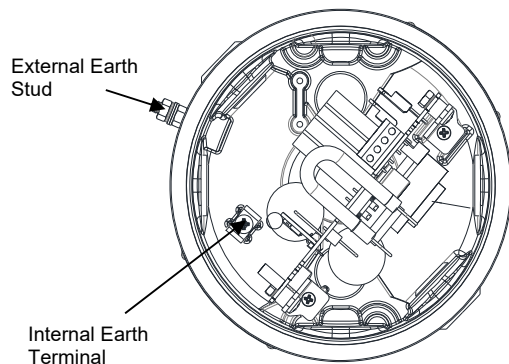

Figure 6: Internal and External Earth Locations.

## 11) Settings

### 11.1 Flash Rate Setting



Warning – high-intensity light source. Avoid looking directly at the light source for extended periods of time.

The D1xB2X beacon can produce different flash patterns as shown in Table 3. The flash patterns are selected by operation of the flash setting DIP switch on the PCB, Figure 7.

For SIL 2 operation, only the 1Hz Flash rate is approved.

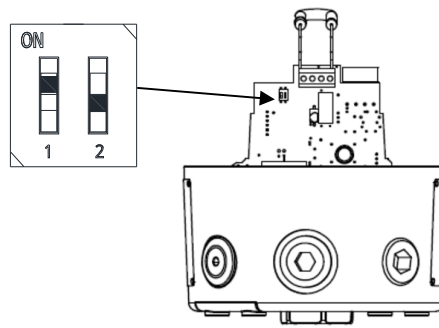

DC Units

Figure 7: DIP Switch Location.

1=ON; 0=OFF

Example shown: 10 = Flashing 1.5Hz  
(Default setting is 00 1Hz)

(\*Setting permitted for use as private mode fire alarm device)

Switch Setting	S1 Mode	SIL Approved
00	1Hz (60FPM)	Yes
—01—	1.33Hz (80FPM)	No
—10—	1.5Hz (90FPM)	No
—11—	Double Flash	No

Table 3: Switch Positions for Flash Patterns

## 12) Interchangeable & Spare Parts



Warning – Hot surfaces. External surfaces and internal components may be hot after operation, take care when handling the equipment.

The Beacon lens cover is interchangeable, contact E2S Ltd for a replacement lens cover available in various colours.

To change the lens cover, unscrew the 4-off M5 socket head screws, spring and flat washers using a 4mm Hex key. Remove the wire guard and replace the old lens cover with the new lens cover.

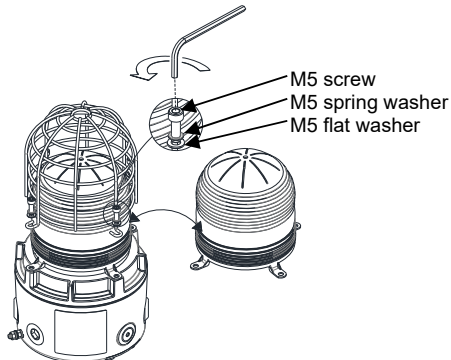

Figure 8: Replacement of beacon lens cover.

Fit the wire guard back onto the housing, over the new lens cover aligning the fixing holes of the guard, lens cover and housing. Refit the fixings to hold into place, the fixings **MUST** be fitted in the order shown above.

## 13) Maintenance, Overhaul & Repair

Maintenance, repair and overhaul of the equipment should only be carried out by suitably qualified personnel in accordance with the current relevant standards:

EN60079-19 / IEC60079-19 Explosive atmospheres -  
Equipment repair, overhaul and reclamation

EN 60079-17 / IEC60079-17 Explosive atmospheres -  
Electrical installations inspection and maintenance

To avoid a possible ELECTROSTATIC CHARGE the unit must only be cleaned with a damp cloth.

Units must not be opened while an explosive atmosphere is present.

If opening the unit during maintenance operations a clean environment must be maintained and any dust layer removed.

Flameproof joints are not intended to be repaired.

## 14) SIL 2 Instruction/Safety Manual

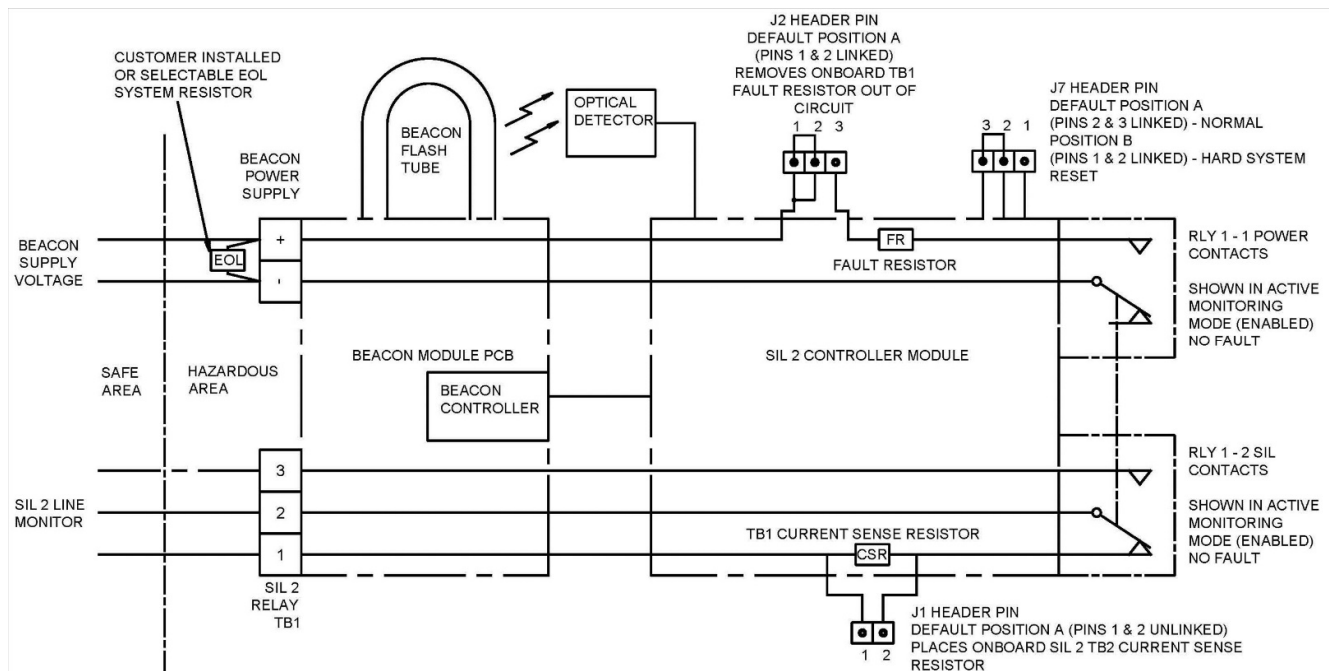

Figure 9: The SIL 2 Module monitors the Beacon and interfaces to the customer plant.

**Warning** – To maintain the integrity of the SIL 2 units the system must be installed, commissioned and used within the parameters outlined in this manual. Failure to comply could result in an unintended unit operation or function.

**Warning** – The unit must be powered in either Standby or Active modes to comply with the SIL 2 approval requirement. If the power is disrupted the unit must be allowed to go through the commissioning cycle to reset. Failure to complete the commissioning cycle and continued disruption in the power supply will generate a fault state which will require the beacon to be reset (see section 17-4).

### SIL 2 System Description

The SIL 2 module monitors the function of the device and provides feedback to the control panel. A fault condition can be communicated by two methods:

- 4 wire installation can be seen as per section 17-1. A SIL 2 system wiring for fault detection in standby and active mode with independent fault contacts.
- 2 wire installation can be seen as per section 17-2. A SIL 2 system by the introduction to the monitoring circuit and linking in an end of line resistor can only register the fault in standby mode.

### 15) SIL 2 System Terms and Function

The SIL 2 Beacon Unit Monitors:

- Standby mode and Active mode
- Health status of power supply
- Beacons correct function and flash pattern

The SIL 2 beacon operates as part of a SIL 2 system. The beacon will after commissioning remain powered in **Standby mode** (reverse polarity) until the beacon is required to operate. When the signalling device is required to operate beacon the polarity is changed back to normal supply and the beacon will go into **Active mode** where it will start to function/flash. When periodically testing the system and beacons, operation is put into **Active mode**.

The system panel or PLC will control whether the system is in either of the main two operational modes.

**Standby Mode** – This is where the power supply polarity is reversed so negative (–ve) is fed to the positive (+) beacon terminal and positive (+) is fed to the negative (–ve) beacon terminal.

In Standby mode the beacon will not flash but the SIL 2 unit is monitoring power supply and is set-up ready to go to Active (alarm) mode.

Power relay RLY1-1 will be open whilst SIL 2 relay RLY1-2 will be closed contact between terminals 1 & 2.

If power is disrupted the SIL 2 unit will go into **Fault mode**, in fault mode the Power relay RLY1-1 will close whilst SIL 2 relay RLY1-2 will become an open circuit between terminals 1 & 2.

**Active Mode** – This is where the power is in normal polarity, positive (+) supplied to the positive (+) beacon terminal and negative (–ve) is supplied to the negative (–ve) beacon terminal.

In Active mode the beacon will output the selected flash pattern. The SIL 2 module checks for the correct flash pattern output and the functionality of the flash signal generation process.

Power relay RLY1-1 will be open whilst SIL 2 relay RLY1-2 will be closed contact between terminals 1 & 2.

The SIL 2 unit will also check for signal polarity.

If a fault is found the SIL 2 unit will go into **Fault mode**.

If power is disrupted the SIL 2 unit will go into **Fault mode**, in fault mode the Power relay RLY1-1 will close whilst SIL 2 relay RLY1-2 will become an open circuit between terminals 1 & 2.

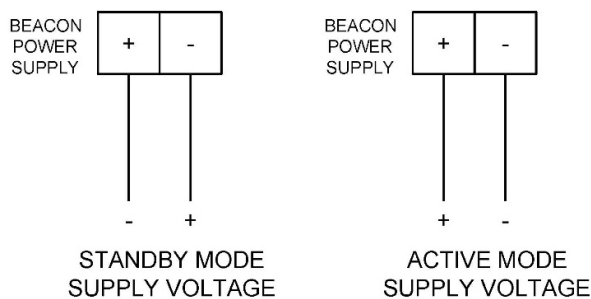

**Fault modes** - The fault modes listed in sections 15-1 & 15-2 will result in a change of state for relays RLY1-1 and RLY1-2.

In fault mode the Power relay RLY1-1 will close whilst SIL 2 relay RLY1-2 will become open be circuit between terminals 1 & 2.

### 15-1 Beacon Failure

- Flash Failure – No flash detected.
- Beacon Controller Failure – No flash trigger pulse detected.
- Flash Rate Failure – Regular 1 Hz flash cycle erratic.

### 15-2 Power Failure / SIL 2 Failure

- SIL 2 Controller Failure – Internal function and system checking flags fault.
- Rapid Power Cycling – System indicates power instability.
- Total Power Failure.

It is possible to reset these faults if they were transitory.

Resetting Failure (by power cycling) - It is possible that the SIL 2 unit can be reset by powering the unit off for a period greater than 20 seconds. On restarting the unit and running through the commissioning cycle the fault may clear.

Resetting Failure (by Hard Reset) - It is possible that the SIL 2 unit can be reset by hard resetting the unit using the reset jumper within the unit (see section 17-4) on hard resetting. On restarting the unit and running through the commissioning cycle, the fault may clear. It is necessary to run the test function cycle again to see if the fault is still evident.

If the hard reset process does not correct the latched fault the alarm horn sounder may require further investigation, please contact your local E2S representative.

### **Commissioning System - Functional start-up of System (Normally in reverse polarity mode)**

When Commissioning system the power must not be disrupted to the SIL 2 Unit within the unit's initialization cycle which is **5 seconds**.

Once past this period the SIL 2 system is fully operational and will be in monitoring the beacon and power in Standby mode.

The relay RLY1-2 on the SIL 2 unit will only remain open for a maximum of 1 second on commissioning start-up. RLY1-2 will subsequently close contacts 1 & 2 indicating healthy operation. Contact 1 & 2 will only remain open in the event of a fault or a loss of power.

### **System Testing (Active Mode normal polarity)**

The SIL 2 system will remain monitoring the power in standby mode until the polarity is changed to normal mode to enable an active system for beacon functional testing.

**Important:** - The polarity must be held in active mode for a period in excess of **15 seconds** to ensure a full system check is performed.

Once the test period has been completed the unit can be switched back to standby mode by reversing the polarity.

If no faults have been found during the test the relays will remain in steady state.

The SIL 2 unit will continue to monitor the power and module function.

**Important:** - The automated test cycle **must** be undertaken on at least a weekly basis to maintain the SIL 2 units reliability.

### **System Activation (Active Mode normal polarity)**

The SIL 2 system will remain monitoring the power in standby mode until the polarity is changed to Active mode to enable an active system for beacon to function as a warning signaling device.

**Important:** - The polarity must be held in active mode for a period in excess of 15 seconds to ensure a full system check is performed whilst in alarm mode, although it is expected that during a system activation this period will be significantly greater.

**Note:** - The fault indication signal on TB1 can take up to 1.5 seconds to indicate system fault.

## 16) SIL 2 Wiring Configuration and Beacon Set-Up

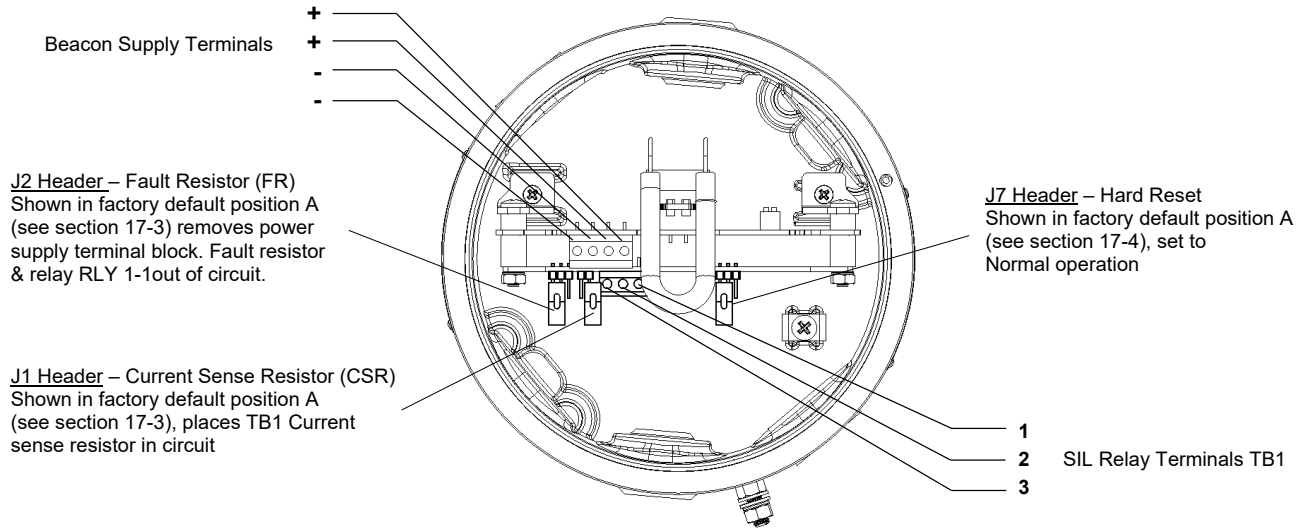

Figure 10: Terminals and header pins for beacon.

Power & Communication with the system control panel can be configured in two ways: - Although it is **highly** recommended that the unit is wired as stated in section 17-1 as a 4-Wire System.

## 17-1) SIL 2 System Wiring for Fault Detection in Standby and Active Mode – 4 Wire Installation (Recommended)

The customer is required to wire into both the beacon power supply terminals and also the SIL 2 Relay terminals TB1.

The power supply terminals only need to have the supply power connected. This will be reverse polarity for monitoring mode and normal polarity for active mode. There is no need to fit an EOL resistor on the power supply terminal as the TB1 is configured to raise a fault alarm in any situation.

Terminal block TB1 is the output from the SIL 2 monitoring relay. Relay RLY 1-2 provides a closed circuit between TB1 terminals 1 & 2 whilst powered. On detection of a fault event this will become open circuit.

The fault will be seen via the SIL 2 TB1 terminals as soon as the fault occurs in either Active or Standby modes.

When no fault is detected the circuit to the SIL 2 TB1 terminals 1 & 2 will include a factory fitted 3.3K Ohm current sense resistor (CSR) in series. When the circuit is driven with 24Vdc the detection current seen is ~7.3mA @ 24V.

The only other fault mode is if the cable goes short circuit where a short will be seen by the panel.

**Option:** Should the fault event output of RLY1-2 be required to operate as a switch, header J1 can be set to link pins 1 & 2 (see Figure 11) thereby removing the 3.3k Ohm current sense resistor (CSR) from the circuit.

**Note:** a cable short circuit will not be detectable in this configuration.

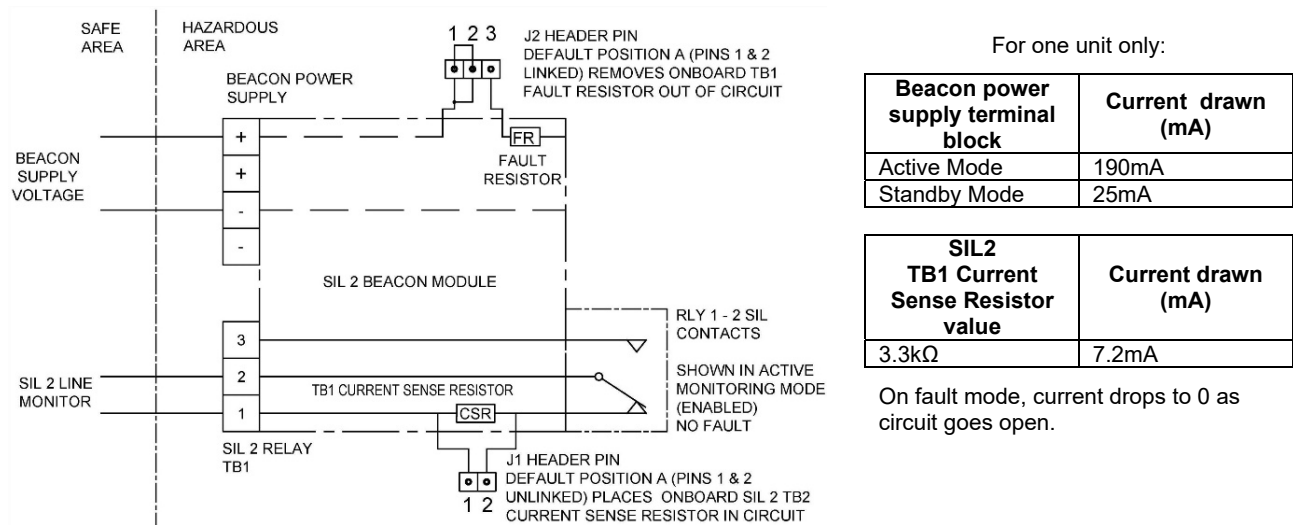

Figure 11: Schematic of SIL 2 system wiring for fault detection in standby and active mode – 4 wire installation.

If multiple SIL 2 alarm horn sounders are to be cabled in series, the monitoring connections differ from that of a single beacon. For more information see manual D197-00-621-IS available from the E2S website.

## 17-2) SIL 2 System Wiring for Fault Detection in Standby Mode Only – 2 Wire Installation

Cabling is required to the positive '+' and negative '-' power input terminals only. Monitoring will occur in standby mode only whilst power supply polarity is reversed. An EOL resistor may be added during installation or can be factory fitted. See Table 4 for EOL resistor value guidance.

The SIL2 monitoring module contains a factory fitted Power Supply Fault Resistor 2.2k Ohm (FR). When a fault is detected the Fault Resistor will be activated. The total measurable resistance of the EOL resistor and Fault Resistor across the power terminals which already has customer EOL resistor (2.2kΩ) in place. This will result in a total fault detection current of 41.8mA @ 24V but can only be detected when unit is in Standby Mode.

**Important:** - The 2 wire configuration will not warn of a fault whilst in Active mode. A fault will only be detectable in standby mode when power supply polarity is reversed.

**Important:** - The 2-wire configuration requires the J2 header pin to be set to position B (see figure 14). Factory default position is A.

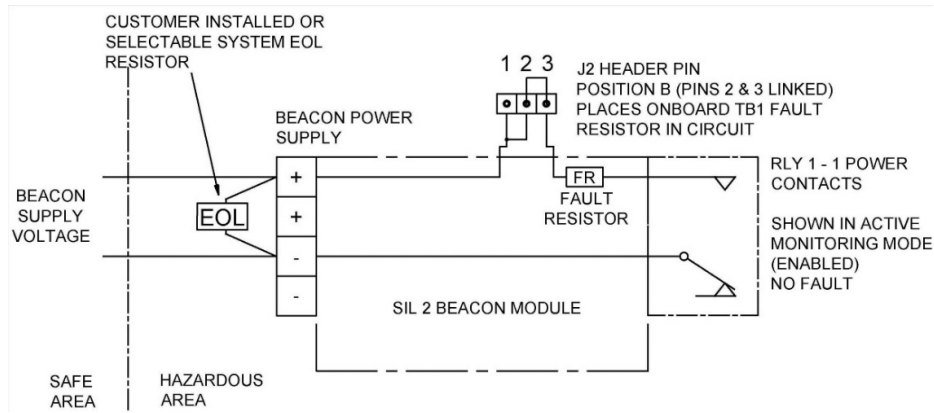

Figure 12: Schematic of SIL 2 system wiring for fault detection in standby mode only – 2 wire installation.

To evaluate the total current drawn from the SIL 2 unit, use the equation below.

$$I \text{ (Total Current drawn)} = I_{FR} \text{ (Current drawn from Fault Resistor)} + I_{EOL} \text{ (Current drawn from Customer EOL resistor)} + I_{SIL} \text{ (Current drawn from SIL board)}$$

In standby mode, where there is no fault, RLY 1-1 is open. This means the voltage only passes through the customer EOL resistor and the current drawn from the SIL 2 board is 25mA. Therefore, the equation for a No Fault scenario is then:

$$I_{NF} \text{ (Standby Mode, Total Current drawn - No Fault)} = I_{FR} \text{ (0mA)} + I_{EOL} \text{ (See table 4)} + I_{SIL} \text{ (25mA)}$$

In standby mode, where there is a fault, the circuit is closed. This means the voltage passes through both the customer EOL resistor and current sense resistor and the current drawn from the SIL 2 board is 20mA. The customer must first calculate the resistance of the two resistors in parallel before applying the currents to the equation. The equation for a Fault scenario is then:

$$I_F \text{ (Standby Mode, Total Current drawn - Fault)} = I_{TR} \text{ (Total Resistance when EOL & FR in parallel)} + I_{SIL} \text{ (20mA)}$$

Standby Mode	Power Supply Fault Resistor		Customer EOL Resistor		(Fault Mode Only)		Current drawn from SIL Board	Total current drawn
	Resistor Value	Current drawn ( $I_{FR}$ )	Resistor Value	Current drawn ( $I_{EOL}$ )	Total resistance	Current drawn ( $I_{TR}$ )		
No Fault	2.2 kΩ	0 mA	2.2 kΩ	10.9 mA	-	-	25 mA	35.9 mA
Fault		-		-	-	1.1 kΩ	21.8 mA	20 mA
No Fault	1.0 kΩ	0 mA	1.0 kΩ	24.0 mA	-	-	25 mA	49.0 mA
Fault		-		-	-	500 Ω	48.0 mA	20 mA
No Fault	2.2 kΩ	0 mA	3.3 kΩ	7.3 mA	-	-	25 mA	32.3 mA
Fault		-		-	-	1.3 kΩ	18.2 mA	20 mA
No Fault	1.8 kΩ	0 mA	3.9 kΩ	6.2 mA	-	-	25 mA	31.2 mA
Fault		-		-	-	1.2 kΩ	19.5 mA	20 mA
No Fault	1.8 kΩ	0 mA	4.7 kΩ	5.1 mA	-	-	25 mA	30.1 mA
Fault		-		-	-	1.3 kΩ	18.4 mA	20 mA
No Fault	2.2 kΩ	0 mA	4.7 kΩ	5.1 mA	-	-	25 mA	30.1 mA
Fault		-		-	-	1.5 kΩ	16.0 mA	20 mA

Table 4: Resistor combinations and the currents drawn when no faults and faults occur.

If multiple SIL 2 alarm horn sounders are to be cabled in series, the monitoring connections differ from that of a single beacon. For more information see manual D197-00-621-IS available from the E2S website.

### 17-3) Header Pins Settings

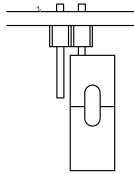
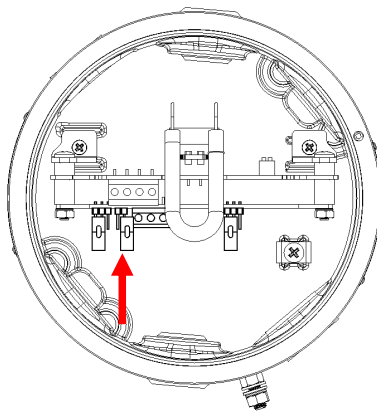

J1 Header Pin - Position A  
 Factory default position (pins 1 & 2 not linked).  
 Places TB1 Current Sense Resistor (CSR) in circuit.  
 As used in 4-Wire Configuration.

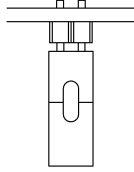

J1 Header Pin - Position B  
 (pins 1 & 2 linked)  
 Removes TB1 Current Sense Resistor (CSR) out of circuit.

Figure 13: J1 Header pin positions – Current Sense Resistor (CSR)

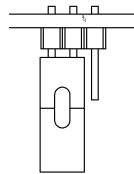
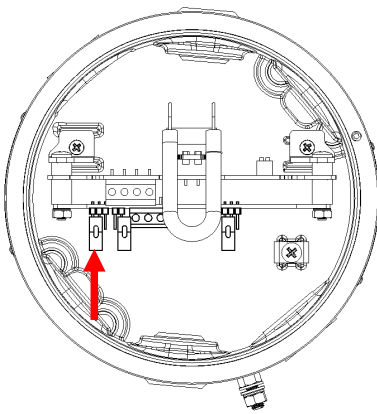

J2 Header Pin - Position A  
 Factory default position (pins 1 & 2 linked).  
 Removes power supply terminal Fault Resistor (FR) &  
 RLY 1-2 out of circuit.  
 As used in 4 -Wire Configuration

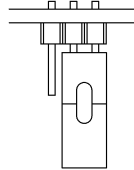

J2 Header Pin - Position B  
 (pins 2 & 3 linked)  
 Places power supply terminal Fault Resistor & RLY 1-2  
 in circuit.  
 As used in 2 – Wire Configuration.

Figure 14: J2 Header pin positions – Fault Resistor (FR)

### 17-4) SIL 2 Hard Reset Function

Power down the unit completely for a minimum of 30 seconds. Move the hard reset header pin (Jumper J7) to reset position B shown. Then power the unit for a minimum of 5 seconds. Power down the unit for 30 seconds and then move the header pin back to Position A.

The unit has now been reset.

If the hard reset process does not correct the latched fault the beacon may require further investigation. Please contact your local E2S representative.

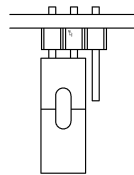
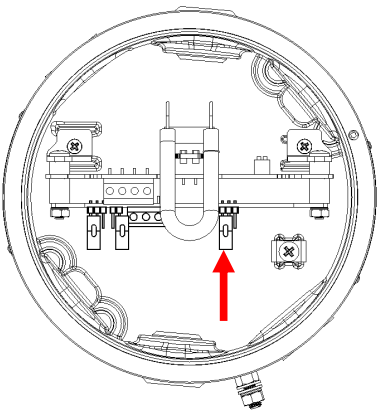

J7 Header Pin - Position A  
 Factory default position (pins 2 & 3 linked).  
 Hard Reset Function disabled – Normal Operation.

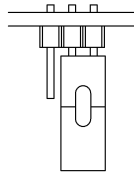

J7 Header Pin - Position B  
 (pins 1 & 2 linked)  
 Hard Reset Enabled - Active reset mode.

Figure 15: J7 Header pin positions – Hard Reset Function

## 18) SIL 2 Specific Unit Mounting Requirements

The beacon should be mounted no closer than 2m from a beacon or light source of similar candela output. This is to ensure false light activation does not occur when the unit is monitoring the light pulse duration and flash failure.

## 19) SIL 2 Reliability Data

Reliability and Functional safety IEC/EN61508 which has been assessed and is considered suitable for use in low demand safety function:

1. Random Hardware Failures and Architectural constraints (route 1H).
2. As an unvoted item (i.e. hardware fault tolerance of 0) at SIL 2.

The product was assessed against failure modes:

- Failure respond to an input by lighting a beacon.
- Spurious light output despite no input.

Integrity in respect of failure to release	SIL 2
Total Failure rate	0.35 pmh
“Hazardous” failure rate (revealed)	0.287 pmh
“Hazardous” failure rate (unrevealed)	0.003 pmh
“Safe” failure rate (revealed)	0.006 pmh
“Safe” failure rate (unrevealed)	0
Diagnostic Coverage	99%
System type	B
Hardware Fault Tolerance	0
Safe Failure Fraction	>99%
PFD (hazardous failure)	$3.7 \times 10^{-5}$
Proof Test Interval	Up to 1 year

## 20) Synchronised Operation

All D1xB2 SIL2 beacons that are connected to the same supply line will have a synchronised flash rate at one flash every second.

## 21) Product Coding for Fault Resistor and Customer EOL Resistor

The customer is able to identify the resistor values chosen on purchase from the product code. This is represented by the last two characters:

D1xB2X05DC024AS1S1R/A-**AFZ**

- The first A character denotes the value of the Fault Resistor (FR). Default value is 2.2K Ohm (Code = A) unless an alternative value is requested when ordering.
- The second F character denotes the value of the Current Sense Resistor (CSR). Default value is 3.3K Ohm (Code = F) unless an alternative value is requested when ordering.
- The third Z character denotes the value of the unit End Of Line Resistor (EOL). By default no EOL resistor is factory fitted (Code = Z). A factory fitted EOL resistor can be specified when ordering.

The values of resistors available are shown in table 5 below.

Code	Resistor Value
A	2.2 kΩ
B	1.0 kΩ
C	1.5 kΩ
D	1.8 kΩ
E	2.7 kΩ
F	3.3 kΩ
G	3.9 kΩ
H	4.7 kΩ
J	5.6 kΩ
K	6.8 kΩ
L	8.2 kΩ
M	11 kΩ
Z	None Fitted

Default resistor coding is as follows:

D1xB2X05DC024AS1S1R/A-**AFZ**

Example of a custom requirement resistor coding:

D1xB2X05DC024AS1S1R/A-**GEF**

Where the (FR) Fault Resistor is (G = 3.9 kΩ)  
(CSR) Current Sense Resistor is (E = 2.7 kΩ)  
(EOL) End Of Line resistor is (F = 3.3 kΩ)

**Note:** To utilise the full monitoring functionality the 4-wire configuration is recommended. An EOL resistor is not required for this configuration.

The alternative 2-wire configuration requires an EOL resistor to be fitted. The EOL resistor can be specified during ordering and factory fitted or selected and fitted during the beacon installation.

See section 9 for EOL resistor location and wattage requirements. E2S recommends a value of 2.2K Ohm. If an alternative value is required, please see section 17-2.

Both the (FR) Fault Resistor and (CSR) Current Sense Resistor are factory fitted and cannot be user replaced.

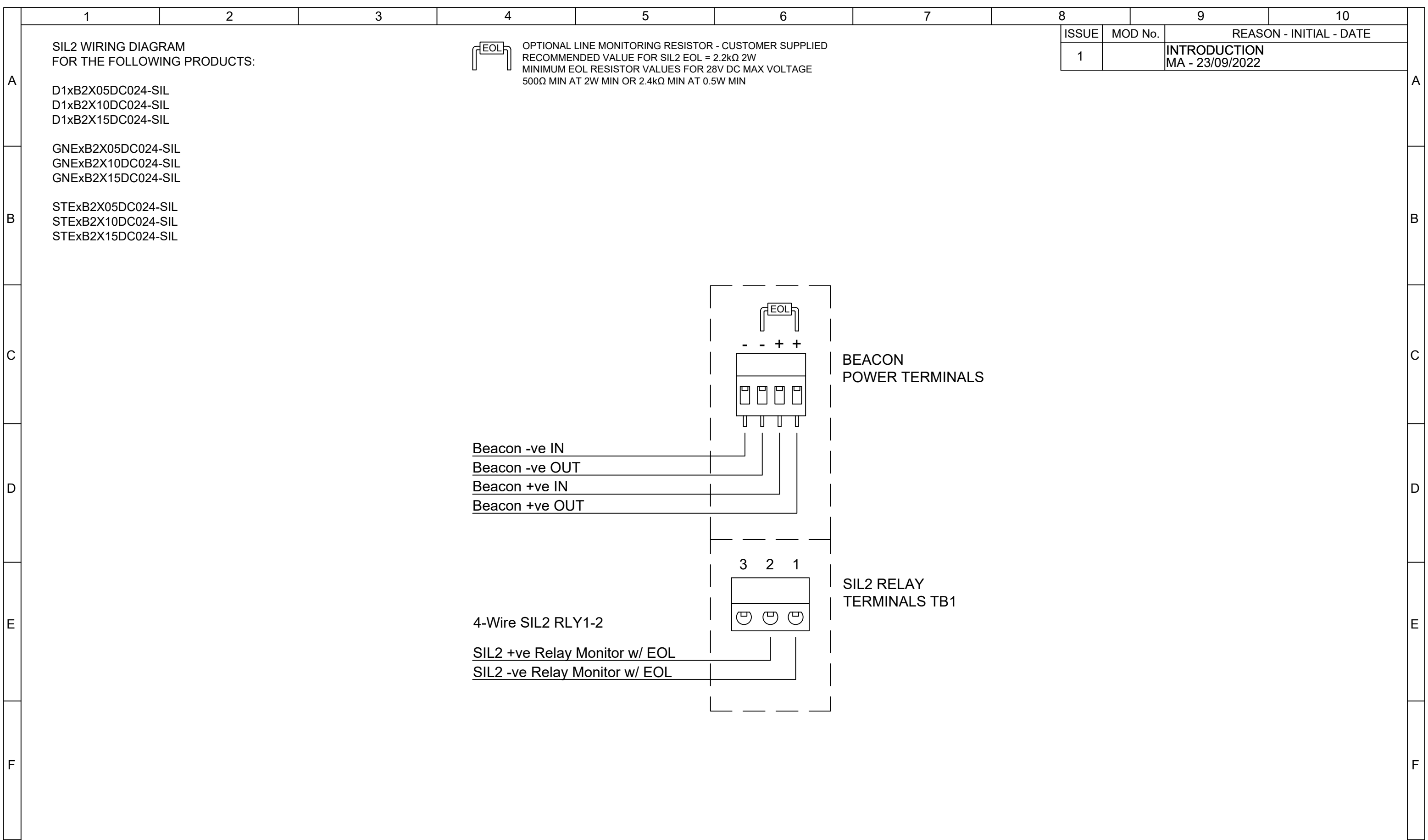

 OPTIONAL LINE MONITORING RESISTOR - CUSTOMER SUPPLIED  
 RECOMMENDED VALUE FOR SIL2 EOL = 2.2kΩ 2W  
 MINIMUM EOL RESISTOR VALUES FOR 28V DC MAX VOLTAGE  
 500Ω MIN AT 2W MIN OR 2.4kΩ MIN AT 0.5W MIN

8	9	10
ISSUE	MOD No.	REASON - INITIAL - DATE
1		INTRODUCTION MA - 23/09/2022

SIL2 WIRING DIAGRAM  
FOR THE FOLLOWING PRODUCTS:



D1xB2X05DC024-SIL  
D1xB2X10DC024-SIL  
D1xB2X15DC024-SIL

GNExB2X05DC024-SIL  
GNExB2X10DC024-SIL  
GNExB2X15DC024-SIL

STExB2X05DC024-SIL  
STExB2X10DC024-SIL  
STExB2X15DC024-SIL

A  
B  
C  
D  
E  
F

A  
B  
C  
D  
E  
F

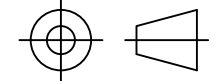
DRAWING TO BS8888:2000 GEOMETRIC TOLERANCES TO ISO1101:1983 LINEAR DIMENSIONAL TOLS ANGULAR DIMENSIONAL TOLS	DRAWN <b>M.ABALOS</b>	DATE <b>23/09/2022</b>	SURFACE FINISH	WEIGHT (Kg)	THIS DRAWING AND ANY INFORMATION OR DESCRIPTIVE MATTER THEREIN IS COMMUNICATED IN CONFIDENCE AND IS THE COPYRIGHT PROPERTY OF EUROPEAN SAFETY SYSTEMS LTD. NEITHER THE WHOLE OR ANY EXTRACT MAY BE DISCLOSED, LOANED, COPIED OR USED FOR MANUFACTURING OR TENDERING PURPOSES WITHOUT THEIR WRITTEN CONSENT.  EUROPEAN SAFETY SYSTEMS LTD. AS PER LATEST DATE OF ISSUE SHOWN ABOVE	 warning signals EUROPEAN SAFETY SYSTEMS LTD IMPRESS HOUSE MANSSELL ROAD ACTON LONDON W3 7QH WWW.E2S.COM	ALL DIMENSIONS IN MM IF IN DOUBT, ASK - DO NOT SCALE		<b>A3</b>	
	CHECKED <b>B.ISARD</b>	DATE <b>23/09/2022</b>	MATERIAL				TITLE <b>D1xB2 / GNExB2 / STExB2 SIL2 DC XENON BEACON WIRING DIAGRAM</b>	SCALE <b>NTS</b>	SHEET <b>1 OF 1</b>	DRAWING NUMBER <b>D191-06-621</b>
	STANDARDS <b>D1x</b>	APPROVED <b>R.N.POTTS</b>	DATE <b>23/09/2022</b>	ALTERNATIVE MATERIAL						



# UKCA Declaration of Conformity



Manufacturer: European Safety Systems Ltd.  
Impress House, Mansell Road, Acton  
London, W3 7QH  
United Kingdom

Equipment Type: D1xB2X05, D1xB2X10, D1xB2X15, D1xB2X21, D1xB2LD2, D1xJ2

Directive UKSI 2016:1107 (as amended by UKSI 2019:696) – Schedule 3A, Part 1 : Product or Protective System Intended for use in Potentially Explosive Atmospheres (UKCA)

Notified Body for UK type Examination (Module B):	UL International (UK) Ltd Notified Body No.: 0843 Unit 1-3 Horizon Kingsland Business Park, Wade Road, Basingstoke, Hampshire RG24 8AH UK
UK-type Examination Certificate (Module B):	UL21UKEX2130X
Notified Body for Quality Assurance Notification / Conformity to EU-type based on quality assurance of the production process (Module D):	Sira Certification Service Notified Body No.: 0518 Rake Lane, Eccleston, Chester CH4 9JN, UK
Quality Assurance Notification (Module D):	CSAE 22UKQAN0046
Provisions fulfilled by the equipment:	II 2G Ex d IIC T6...T3 Gb II 2D Ex tb IIIC T95°C...T169°C Db
Standards applied:	EN 60079-0:2018 EN 60079-1:2014 EN 60079-31:2014 IP6X Dust Protection to EN60079-0 / EN60079-31

Regulation EU No. 305/2011: Construction Products Regulation (CPR) –part codes listed below only – 1Hz Flash Mode only

Notified Product Certification Body for Certificate of Constancy of Performance or EC Type Examination Certificate and continuous surveillance, assessment and evaluation of factory production control:	BRE Global Limited Notified Body No.: 0832 Bucknalls Lane, Garston, Watord, Hertfordshire, UK, WD25 9XX
Certificate of Constancy of Performance or EC Type Examination Certificate:	0832-UKCA-CPR-F41783 (D1xB2X05DC024***A1R/C, D1xB2X05DC024***A1G/C only)  0832-UKCA-CPR-F1854 (D1xB2X05DC024***A1R/R, D1xB2X05DC024***A1G/R only)
Standards applied:	EN 54-23:2010

UK Merchant Shipping, Marine Equipment Regulation (MER) 2016 SI 2016/1025– part codes specified only - D1xB2X05DC024\*\*\*A1R/C, D1xB2X05DC024\*\*\*A1G/C, D1xB2X05DC024\*\*\*A1R/R, D1xB2X05DC024\*\*\*A1G/R

Notified Body for UK type Examination (Module B) and Conformity to UK-type based on quality assurance of the production process (Module D):	DNV UK Notified Body No.: 0097 DNV, UK
UK-Certificate Type Examination (Module B):	MERB000085K
UK Certificate of Conformity for the Quality Assurance System (Module D):	MERD00000GV
Standards applied:	EN 54-3:2014 incl. A1: 2019 EN 54-23:2010 IEC 60092-504: 2016 IEC 60533: 2015



# UKCA Declaration of Conformity



## Directive 2014/30/EU: Electromagnetic Compatibility Directive (EMC)

Standards applied:

EN 61000-6-1:2007  
EN 61000-6-2:2005  
EN 61000-6-3:2007 / A1:2011 / AC: 2012  
EN 61000-6-4:2007 / A1: 2011

## Directive 2011/65/EU: Restriction of the use of certain hazardous substances in electrical and electronic equipment (RoHS)

The product and all the components contained within it are in accordance with the restriction of the use of hazardous substances in electrical and electronic equipment, including amendment by Directive 2015/863/EU.

## Regulation (EC) 1907/2006: Registration, Evaluation, Authorisation and Restriction of Chemicals (REACH)

The product and all the components contained within it are free from substances of very high concern.

## Other Standards and Regulations

EN 60529:1991 + A1:2000 + A2:2013. - Degrees of protection provided by enclosures (IP code) – enclosure rated IP66/67

---

On behalf of European Safety Systems Ltd., I declare that, on the date the equipment accompanied by this declaration is placed on the market, the equipment conforms with all technical and regulatory requirements of the above listed directives, regulations and standards.

This Declaration is issued under the sole responsibility of the manufacturer.

Desmond Gayler  
Quality Assurance Manager

Document No.: DC-096\_Issue\_C  
Date and Place of Issue: London, 18/03/2024

# EU Declaration of Conformity



**Manufacturer:** European Safety Systems Ltd.  
Impress House, Mansell Road, Acton  
London, W3 7QH  
United Kingdom

**Authorised Representative:** E2S Warnsignaltechnik UG  
Charlottenstrasse 45-51  
72764 Reutlingen  
Germany

**Equipment Type:** D1xB2X05, D1xB2X10, D1xB2X15, D1xB2X21, D1xB2LD2, D1xJ2

---

## Directive 2014/34/EU: Equipment and Protective Systems for use in Potentially Explosive Atmospheres (ATEX)

Notified Body for EU type Examination (Module B):	UL International Demko A/S Notified Body No.: 0539 Borupvang 5A, 2750 Ballerup, Denmark
EU-type Examination Certificate (Module B):	DEMKO 19 ATEX 2009X Rev. 1
Notified Body for Quality Assurance Notification / Conformity to EU-type based on quality assurance of the production process (Module D):	Sira Certification Service Notified Body No.: 2813 CSA Group Netherlands B.V, Utrechtseweg 310, 6812 AR, Arnhem, Netherlands
Quality Assurance Notification (Module D):	SIRA 05 ATEX M342
Provisions fulfilled by the equipment:	II 2G Ex d IIC T6...T3 Gb II 2D Ex tb IIIC T95°C...T169°C Db
Standards applied:	EN 60079-0:2018 EN 60079-1:2014 EN 60079-31:2014 IP6X Dust Protection to EN60079-0 / EN60079-31

## Regulation EU No. 305/2011: Construction Products Regulation (CPR) –part codes listed below only – 1Hz Flash Mode only

Notified Product Certification Body for Certificate of Constancy of Performance or EC Type Examination Certificate and continuous surveillance, assessment and evaluation of factory production control:	BRE Global Assurance (Ireland) Limited Notified Body No.: 2831 DCU Alpha, Old Finglas Road, Glasnevin, Dublin, D11 KXN4
Certificate of Constancy of Performance or EC Type Examination Certificate:	2831-CPR-F4859 (D1xB2X05DC024***A1R/C, D1xB2X05DC024***A1G/C only) 2831-CPR-F4899 (D1xB2X05DC024***A1R/R, D1xB2X05DC024***A1G/R only)
Standards applied:	EN 54-23:2010

## Directive 2014/90/EU: Marine Equipment Directive (MED) – part codes specified only – D1xB2X05DC024\*\*\*A1R/C ; D1xB2X05DC024\*\*\*A1R/R ; D1xB2X05DC024\*\*\*A1G/C ; D1xB2X05DC024\*\*\*A1G/R

Notified Body for EU type Examination (Module B) and Conformity to EU-type based on quality assurance of the production process (Module D):	DNV AS Notified Body No.: 0575 DNV Høvik, Norway
EU-Certificate Type Examination (Module B):	MEDB000085K
EU Certificate of Conformity for the Quality Assurance System (Module D):	MEDD00000GV
Standards applied:	EN 54-3:2014 incl. A1: 2019 EN 54-23:2010 IEC 60092-504: 2016

# EU Declaration of Conformity



IEC 60533: 2015

## Directive 2014/30/EU: Electromagnetic Compatibility Directive (EMC)

Standards applied:

EN IEC 61000-6-1:2019 & IEC 61000-6-1:2016  
EN IEC 61000-6-2:2019 & IEC 61000-6-2:2016  
EN IEC 61000-6-3:2021 & IEC 61000-6-3:2020  
EN IEC 61000-6-4:2019 & IEC 61000-6-4:2018

## Directive 2011/65/EU: Restriction of the use of certain hazardous substances in electrical and electronic equipment (RoHS)

The product and all the components contained within it are in accordance with the restriction of the use of hazardous substances in electrical and electronic equipment, including amendment by Directive 2015/863/EU.

## Regulation (EC) 1907/2006: Registration, Evaluation, Authorisation and Restriction of Chemicals (REACH)

The product and all the components contained within it are free from substances of very high concern.

## Other Standards and Regulations

EN 60529:1991 + A1:2000 + A2:2013. - Degrees of protection provided by enclosures (IP code) – enclosure rated IP66/67

---

On behalf of European Safety Systems Ltd., I declare that, on the date the equipment accompanied by this declaration is placed on the market, the equipment conforms with all technical and regulatory requirements of the above listed directives, regulations and standards.

This Declaration is issued under the sole responsibility of the manufacturer.

A blue ink signature of Desmond Gayler, written in a cursive style.

Desmond Gayler  
Quality Assurance Manager

Document No.: DC-077\_Issue\_G  
Date and Place of Issue: London, 01/09/2023