

INSTRUCTION MANUAL

D1xS1

Alarm Horn Sounder

Class I, Zone 1, 2, 21 & 22

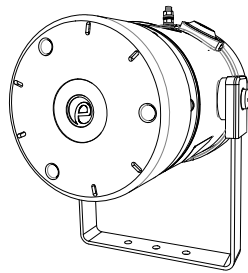

D1xS1R

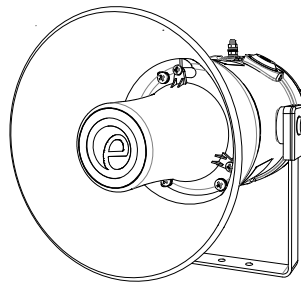

D1xS1F

1) Product Table

Unit Type Code	Nominal Input Voltage	Nominal Input Current	Voltage Range	Sound Pressure Level dB(A) [‡]	
				Max [*]	Nom [†]
D1xS1RDC024-A	12Vdc	221mA	11.5-54Vdc	110	105
	24Vdc	185mA			
	48Vdc	115mA			
D1xS1RAC230-A	115Vac	73mA	100-240Vac 50/60Hz	115	110
	230Vac	48mA			
D1xS1FDC024-A	12Vdc	221mA	11.5-54Vdc	115	110
	24Vdc	185mA			
	48Vdc	115mA			
D1xS1FAC230-A	115Vac	73mA	100-240Vac 50/60Hz	115	110
	230Vac	48mA			

*Max = Tone 4
†Nom. = Tone 44
The table shows the input current taken by the various sounders.
The current levels shown above are for the 440Hz Continuous tone @ nominal input voltage.
Nominal current at nominal voltage.
[‡]For EN54-3, please refer to Construction Product Regulations section

Table 1: Electrical Ratings.

2) Warnings



CAUTION

TO REDUCE THE RISK OF IGNITION OF HAZARDOUS ATMOSPHERES:

DISCONNECT FROM SUPPLY BEFORE OPENING.
KEEP TIGHTLY CLOSED WHEN IN OPERATION.

WARNING

FIT SEALING FITTING IN CONDUIT RUNS WITHIN 18 INCHES FROM ENCLOSURE.

EQUIPMENT MUST NOT BE INSTALLED WITH THE HORN FACING UPWARDS OF HORIZONTAL

DO NOT OPEN WHEN AN EXPLOSIVE ATMOSPHERE IS PRESENT

DO NOT OPEN WHEN ENERGISED

POTENTIAL ELECTROSTATIC CHARGING HAZARD - CLEAN ONLY WITH A DAMP CLOTH

ENCLOSURE ENTRIES: TWIN M20 X 1.5 / SINGLE 1/2" NPT

ATEX/IECEx & UKEx INSTALLATIONS: IF TEMPERATURE EXCEEDS 70°C AT ENTRY OR 80°C AT BRANCHING POINT USE SUITABLE RATED CABLE AND GLANDS

ATTENTION

POUR RÉDUIRE LE RISQUE D'INFLAMMATION DES ATMOSPHÈRES DANGEREUSES :

COUPER L'ALIMENTATION AVANT OUVERTURE.
CONSERVER FERMÉ PENDANT LE FONCTIONNEMENT.

AVERTISSEMENT

CONDUITS DOIVENT ÊTRE SCELLES EN MOINS DE 18 POUCHES.
ÉQUIPEMENT NE DOIT PAS ÊTRE INSTALLÉ AVEC LE KLAXON

TOURNÉE VERS LE HAUT DE HORIZONTAL.

NE PAS OUVRIR UN PRÉSENCE D'ATMOSPHÈRE EXPLOSIVE
NE PAS OUVRIR ÉNERGIE

DANGER POTENTIEL CHARGE ÉLECTROSTATIQUE - NETTOYER

UNIQUEMENT AVEC UN CHIFFON HUMIDE

ENTRÉES DE BOÎTIER: 2 x M20 X 1.5 / 1 x 1/2" NPT

ATEX/IECEx & UKEx INSTALLATIONS : SI LA TEMPÉRATURE DÉPASSE 70°C À L'ENTRÉE OU 80°C AU POINT DE BRANCHEMENT, UTILISER UN CÂBLE ET DES JOINTS D'ÉTANCHÉITÉ APPROPRIÉS

3) Marking & Rating Information

3.1 UL Certification

All Sounders comply with the following standards:

UL 464A (Ed 1) – Audible Signal Appliances for General Signaling Use
CSA C22.2 No. 205-17 (Ed 3) –Signal Equipment

D1xS1-DC024-A Sounders also comply with the following standards:

UL 464 (Ed 10) – Audible Signaling Devices for Fire Alarm and Signaling Systems, Including Accessories.
CAN/ULC-S525 (Ed 4) – Audible Signaling Devices for Fire Alarm and Signaling Systems, Including Accessories.

See relevant sections further down.

The D1xS1 Alarm Horns comply with the following standards for hazardous locations:

3.2 Class/Division Ratings for US & Canada

Standards	
Class I UL 1203 & CSA C22.2 No 30-M1986	
Class Division Ratings for US (NEC)	
Model No:	Rating
D1xS1-DC024-A / D1xS1-AC230-A	Class I Div 1 ABCD T5 Ta -55°C to +85°C Class I Div 1 ABCD T6 Ta -55°C to +75°C
Class Division Ratings for Canada (CEC)	
Model No:	Rating
D1xS1-DC024-A	Class I Div 1 ABCD T5 Ta -55°C to +85°C Class I Div 1 ABCD T6 Ta -55°C to +75°C
D1xS1-AC230-A	Class I Div 1 ABCD T6 Ta -55°C to +40°C
Class Zone Ratings for US (NEC)	
Model No:	Rating
D1xS1-DC024-A / D1xS1-AC230-A	Class I Zone 1 IIC T5 Ta -55°C to +85°C Class I Zone 1 IIC T6 Ta -55°C to +75°C
Class Zone Ratings for Canada (CEC)	
Model No:	Rating
D1xS1-DC024-A	Class I Zone 1 IIC T5 Ta -55°C to +85°C Class I Zone 1 IIC T6 Ta -55°C to +75°C
D1xS1-AC230-A	Class I Zone 1 IIC T6 Ta -55°C to +40°C
Installation must be carried out in compliance with the National Electric Code / Canadian Electric Code	

3.3 ATEX / IECEx & UKEx Ratings

Standards	
EN60079-0:2018/IEC60079-0:2017 (ed.7): Explosive Atmospheres - Equipment General Requirements. EN60079-1:2014/IEC60079-1:2014 (ed.7): Explosive Atmospheres - Equipment Protection by Flameproof Enclosures "d". EN60079-31:2014/IEC60079-31:2013 (ed.2): Explosive Atmospheres - Equipment Dust Ignition Protection by enclosure "t".	
Model No:	Rating
D1xS1-DC024-A	Ex db IIC T5 Gb Ta -55°C to +75°C Ex db IIC T6 Gb Ta -55°C to +70°C Ex tb IIIC T84°C Db Ta -55°C to +75°C
D1xS1-AC230-A	Ex db IIC T5 Gb Ta -55°C to +75°C Ex db IIC T6 Gb Ta -55°C to +70°C Ex tb IIIC T82°C Db Ta -55°C to +75°C
See Product table for electrical ratings of each unit model	

Certificate No.

DEMKO 19ATEX2141X
IECEX ULD 19.0008X
UKEx UL UL21UKEX2132X

Epsilon x
Equipment Group
and Category:

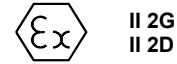

CE Marking and
Notified Body No.



UKCA Marking and
Notified Body No.



3.4 Marine MED and MER Approval

MED Marking and
Notified Body No.

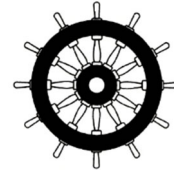

MER Marking and
Notified Body No.



D1xS1FDC024 units have been tested and approved for the installation on ships in the following locations:

Temperature D: Location (-25°C to +70°C)
Vibration A: +/-1mm / 0.7g general applications
EMC B: Bridge and open deck zone
Enclosure: IP66 Outdoor

3.5 DNV TA Approval

D1xS1 units have been tested and approved for the installation on ships in the following locations:

Temperature: Class A,B,C & D (all locations including open decks and masts)
Humidity: Class A & B (all locations)
Vibration: Class A (all locations except installation on machinery such as combustion engines, compressors, pumps, including piping on such machinery, and masts)
EMC: Class A & B (all locations including open decks and bridge)
Enclosure: Class A, B & C – IP66 (all locations expect submerged applications and bilges)

All D1xS1 units in all flare and voltage options carries Type Approval by DNV to the following guidelines:

Class Guideline DNV-CG-0339:
Environmental test specification for electrical, electronic and programmable equipment and systems

4) Zones, Gas Group, Category and Temperature Classification

The units can be installed in locations with the following conditions:

Area Classification Gas	
Zone 1	Explosive gas air mixture likely to occur in normal operation.
Zone 2	Explosive gas air mixture not likely to occur in normal operation, and if it does, it will only exist for a short time.
Gas Groupings	
Group IIA	Propane
Group IIB	Ethylene
Group IIC	Hydrogen and Acetylene
Temperature Classification for Gas Applications	
T1	450° C
T2	300° C
T3	200° C
T4	135° C
T5	100° C
T6	85° C (D1xS1 up to 70° C ambient)
Area Classification Dust	
Zone 21	Explosive dust air mixture likely to occur in normal operation.
Zone 22	Explosive dust air mixture not likely to occur in normal operation, and if it does, it will only exist for a short time.
Dust Groupings	
Group IIIA	Combustible Dusts
Group IIIB	Non-Conductive Dusts
Group IIIC	Conductive Dusts
Equipment Category	
2G, 2D	
Equipment Protection Level	
Gb, Gc, Db, Dc	
Maximum Surface Temperature for Dust Applications	
84° C (D1xS1-DC024-A) 82° C (D1xS1-AC230-A)	
Ambient Temperature Range	
-55° C to +75° C (-67° F to +167° F)	
IP Rating	
IP66 to EN60529 4 / 4X / 3R / 13 to UL50E / NEMA250	
Installation must be carried out in compliance with the latest issue of the following standards:	
EN60079-14 / IEC60079-14: Explosive atmospheres - Electrical installations design, selection and erection	
EN60079-10-1 / IEC60079-10-1: Explosive atmospheres - Classification of areas. Explosive gas atmospheres	
EN60079-10-2 / IEC60079-10-2: Explosive atmospheres - Classification of areas. Explosive dust atmospheres	

5) Specific Conditions of Installation

ATEX/IECEX & UKEx Installations:

The cable entries have two M20 x 1.5 – 6H entry thread and a single ½” NPT thread. If the installation is made using cable glands, only suitably rated ATEX/IECEX or UKEx certified cable glands must be used. They must be suitable for the type of cable being used and also meet the requirements of the current installation standards EN 60079-14 / IEC60079-14.

If the installation is made using conduit, openings must have a sealing fitting connected as close as practical to the wall of the enclosure, but in no case more than the size of the conduit or 50mm, whichever is the lesser.

Any unused cable entries must be closed with suitably rated and UKEx certified blanking plugs.

For high ambient temperatures the cable entry temperature may exceed 70° C or the cable branching point temperature may exceed 80° C and therefore suitable heat resisting cables and cable glands must be used, with a rated service temperature at least as stated below:

Minimum Ratings of Cables & Cable Glands					
Max Ambient Temp (°C)	55	60	65	70	75
D1xS1-DC024-A Min. Rating (°C)	70	75	80	85	90
D1xS1-AC230-A Min. Rating (°C)		70	75	80	85

Table 2: ATEX/IECEX & UKEx Min. Ratings of Cables & Cable Glands.

NEC / CEC Installations:

The cable entries have two M20 x 1.5 – 6H entry thread and a single ½” NPT thread. If the installation is made using cable glands, only suitably rated and UKEx certified cable glands must be used. They must be suitable for the type of cable being used and also meet the requirements of the current installation standards for NEC & CEC.

If the installation is made using conduit, openings must have a sealing fitting connected within 18” of enclosure.

Any unused cable entries must be closed with suitably rated and certified blanking plugs.

All Installations:

The plastic horn is not anti-static and the metallic enclosure has a non-conductive coating. These may generate an ignition-capable level of electrostatic charges under certain extreme conditions. The user should ensure that the equipment is not installed in a location where it may be subjected to external conditions that might cause a build-up of electrostatic charges on non-conducting surfaces.

Only the explosionproof cover is to be used for access to the enclosure for installation, service and maintenance.

6) Specific Conditions for Safe Use

Flameproof threaded joints and cemented joints are not permitted to be repaired.

7) Product Mounting and Access

7.1 Mounting

The D1x Alarm Horn may be secured to any flat surface using at least two of the three or four 7mm fixing holes. The enclosure provides IP66 protection and is suitable for installation in exterior locations providing it is positioned so that water cannot collect in the horn, and the cable entry is sealed.

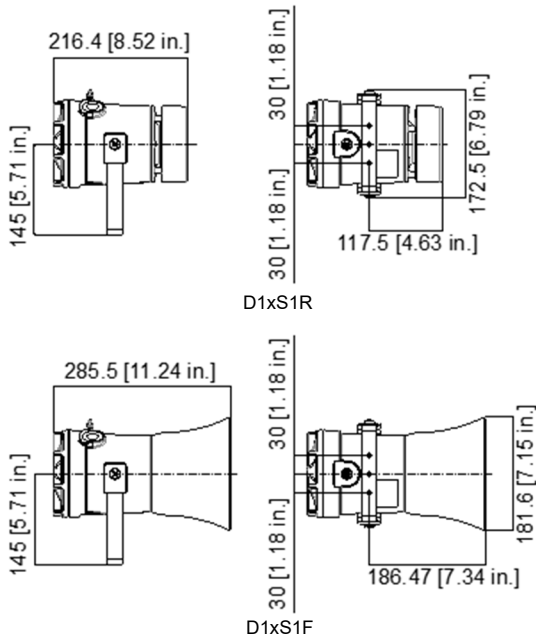
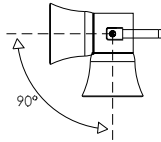

Fig 1: Mounting Locations

The Equipment must not be installed with the horn facing upwards of horizontal.



7.2 Installation procedure

- Secure the D1x unit to a flat surface via the three 7mm fixing holes in the mounting bracket.
- Remove the explosionproof cover of the alarm horn by unscrewing it, taking care not to damage the explosionproof threads in the process (Refer to section 7.4).
- Fit an M20/NPT suitably rated cable gland or conduit entry into the hole in the enclosure and connect the field wiring to the appropriate alarm horn terminals as shown in D190-06-005 (AC) or D190-06-001. (DC). The power supply terminals are duplicated so that units may be connected in parallel. An end of line monitoring resistor may be fitted to DC units only (see section 10). If the second and third M20/NPT entries are not used, suitably rated stopping plugs must always be fitted.
- Replace the explosionproof cover of the loudspeaker, taking care not to damage the explosionproof threads. Tighten fully.

7.3 Hornless Variants

The D1x Sounder is also available as a variant with no horn fitted in the factory. The Horn threaded nose portion has a fitment thread of 1-3/8" – 18 UNF (to BS1580 or ANSI B1.1). The customer is responsible for sourcing and correctly fitting a suitable horn that meets all of the relevant safety requirements.

7.4 Access to the Explosionproof Enclosure

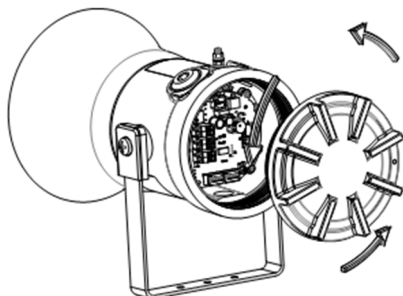

Fig 2: Accessing the enclosure

To access the Ex d chamber, loosen the M4 grub screw on the sounder cover. Open the enclosure by turning the sounder cover counterclockwise and remove the cover. Take extreme care not to damage the explosionproof threads in the process.

On completion of the installation the flameproof threaded joint should be inspected to ensure that they are clean and that they have not been damaged during installation.

Ensure the O-ring seal is in place and undamaged.

When fitting the flameproof cover ensure the thread is engaged correctly. Fully tighten the cover all the way, ensure no gap is visible between the cover and base of the sounder enclosure.

8) Installation Requirements

8.1 Safe Installation Requirements



Warning – High voltage may be present, risk of electric shock.
DO NOT open when energised, disconnect power before opening.

The sounder must only be installed by suitably qualified personnel in accordance with the latest issues of the relevant standards.

The product must only be installed by suitably qualified personnel in accordance with the latest issues of the relevant standards.

The installation of the units must also be in accordance with the NEC / CEC and any local regulations and should only be carried out by a competent electrical engineer who has the necessary training.

8.2 Cable Selection and Connections

Electrical connections are to be made into the terminal blocks on the PCBA, using solid wire 0.5-4mm² / AWG 20-12 or stranded wire, sizes 0.5-2.5mm² / AWG 24-14. Wire insulation needs to be stripped 8mm. Wires may be fitted securely with crimped ferrules. Terminal screws need to be tightened down with a tightening torque of 0.45 Nm / 3.5 Lb-in.

When selecting the cable size, consideration must be given to the input current that each unit draws (see table 1), the number of sounders on the line and the length of the cable runs. The cable size selected must have the necessary capacity to provide the input current to all the sounders connected to the line.

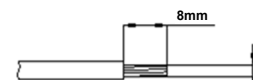

AC: 1.0 - 2.5mm² / AWG18 - AWG12
DC: 0.2 - 2.5mm² / AWG24 - AWG12

Fig 3: Wire Preparation.

When connecting wires to the terminals great care should be taken to dress the wires so that when the cover is inserted into the chamber the wires do not exert excess pressure on the terminal blocks. This is particularly important when using cables with large cross-sectional areas such as 2.5mm².

8.3 Earthing

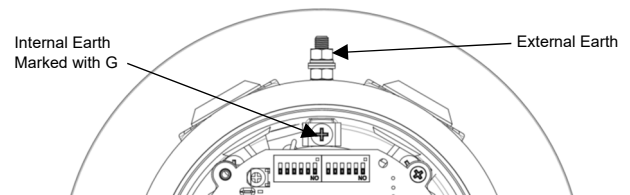

Fig. 4 Earth Locations

Please note that for AC supply voltage product versions the Earth terminal on the PCBA does not provide an earth connection to the

product enclosure. The enclosure must be independently earthed using either the external or internal earth fixing point, (see fig 4 and notes below).

The unit has both a primary internal and secondary external earth fixing point.

Internal earth connections should be made to the internal Earth terminal in the base of the housing using a ring crimp terminal to secure the earth conductor under the earth clamp. The earth conductor should be at least equal in size and rating to the incoming power conductors but at least a minimum of 0.82mm² / 18AWG in size.

External earth connections can be made to the M5 earth stud (see Fig. 4), using a ring crimp terminal to secure the earth conductor to the earth stud. The external earth conductor should be at least 4mm² in size.

The external earth crimp ring should be located between the two M5 plain washers provided and securely locked down with the M5 spring washer and M5 nut.

8.4 Cable Glands, Blanking Elements & Adapters

Ingress Protection

If a high IP (Ingress Protection) rating is required then a suitable sealing washer must be fitted under the cable glands or blanking plugs. A minimum ingress protection rating of IP6X must be maintained for installations in explosive dust atmospheres.

To maintain the ingress protection rating and mode of protection, the cable entries must be fitted with suitably rated cable entry and/or blanking devices during installation.

If entries are fitted with adaptors they must be suitably rated for the application. Fitting of blanking elements into adaptors is not permitted.

Adapters

The D1x sounder range can be supplied with the following types of adapters:

- M20 to 1/2" NPT
- M20 to 3/4" NPT
- M20 to M25

It is important to note that stopping plugs cannot be fitted onto adapters, only directly onto the M20 entries.

9) Settings

Following illustrations show the settings available for D1xS1 Alarm Horn Sounders. See schematic diagram D190-06-001 for details.

9.1 Configuration

See Table 1 for product power supply and Sound Pressure Levels (SPL).

Configuration for DC Units

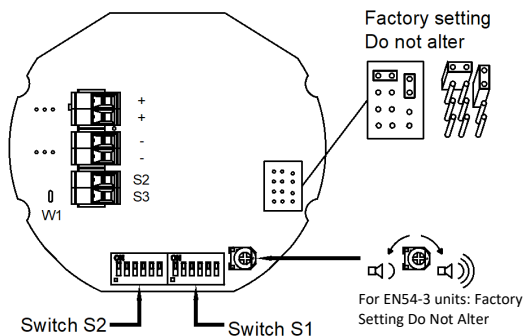

Fig 5: DC PCBA.

Configuration for AC Units

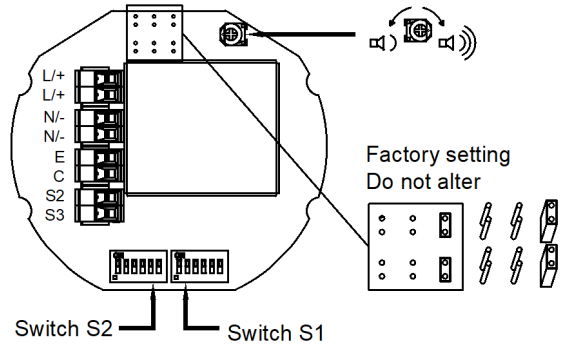

Fig 6: AC PCBA .

9.2 Stage Switching Polarity (DC Units)

Switching from positive switching (default) to negative switching - DC Only.

NOTE: Max supply is 33V DC – if higher DC voltage is required, use Negative switching.

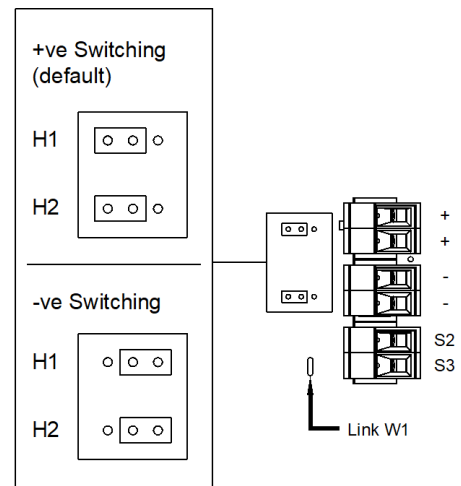
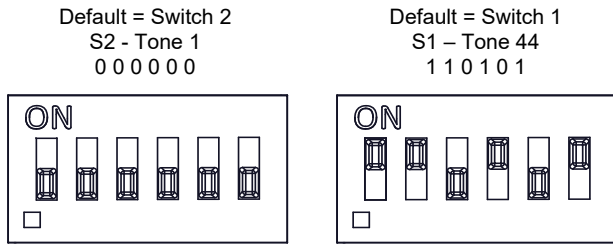

Figure 7: Stage Switching Polarity.

9.3 Tone Selection

The D1x Alarm Horn Sounders have 64 different tones that can be selected independently for the first and second stage alarms. The tones are selected by operation of the tone setting DIP switch 1 & DIP 2witch 2 (see fig 8) on the PCB, for stage 1 and stage 2 respectively.



(ON = 1, OFF = 0)

Figure 8: DIP switch configuration

The sounder can also be switched to sound the third and fourth stage alarm tones.

The tone table (D221-95-001-IS) shows the switch positions for the 64 tones on first and second stages and which tones are available for the third and fourth stages dependent on the Stage 1 DIP switch setting.

Following table (Table 3) is a summary of DC: D190-06-001; AC: D190-06-005 wiring options.

Config.	Voltage	Configuration Description	Features	Product Option Identifier
1a	DC	Single Stage Configuration	<ul style="list-style-type: none"> Line monitoring (refer section 10) Positive Switching 	1
1b	DC	Two Stage Configuration	<ul style="list-style-type: none"> Common Negative Positive Switching Line monitoring (refer section 10) 	1
1c	DC	Three/Four Stage Configuration	<ul style="list-style-type: none"> Common Negative Positive Switching Line monitoring (refer section 10) 	1
2	DC	Three/Four Stages. Voltage Free 2nd, 3rd & 4th Stage Activation Configuration	<ul style="list-style-type: none"> Common Positive Customer Set H1 & H2 to Negative Switching Line monitoring (refer section 10) 	1
3	DC	Two Stage Configuration	<ul style="list-style-type: none"> Independent Stage Input Reverse Polarity Monitoring Stage 1 & 2 (refer to section 10) 	1
4	DC	Two Stage Configuration	<ul style="list-style-type: none"> Independent power input for alarm stage activation of Stage 1 & 2. Line monitoring available for each alarm stage – use suitable monitoring relays/modules. Line monitoring requires common negative between each power input. Line monitoring maximum voltage: 4Vdc. Not to be used for reverse polarity line monitoring. 	Y
5	DC	Two/Three Stage Voltage Free Activation Configuration	<ul style="list-style-type: none"> Line monitoring (refer section 10) 	K
6	DC	Three/Four Stage Configuration	<ul style="list-style-type: none"> Independent power input for alarm stage activation of Stage 1, 2 and 3 Stage 4 can be activated via activation of Stage 2 and Stage 3 simultaneously Line monitoring available for Stage 1, 2 & 3 alarm stage – use suitable monitoring relays/modules Line monitoring requires common negative between each power input Line monitoring maximum voltage: 4Vdc Not to be used for reverse polarity line monitoring 	V
1a	AC	Single Stage Configuration		1
1b	AC	Three/Four Stage Configuration		1
2	AC	Two/Three Stage Voltage Free Activation Configuration		K

Table 3: Summary of Wiring Options. See Document D190-06-001 for DC Schematic Diagrams; D190-06-005 for AC Schematic Diagrams.

10) End of Line Monitoring (DC Units)

10.1 Standard DC End Of Line Monitoring

All DC units have a blocking diode fitted in their supply input lines. An end of line monitoring diode or an end of line monitoring resistor can be connected across the +ve and -ve terminals in the flameproof chamber.

If an end of line resistor is used it must have a minimum resistance value of:

Minimum Resistance 3k3 ohms Minimum Power 0.5W
 Minimum Resistance 500 ohms Minimum Power 2W

The resistor must be connected directly across the +ve and -ve terminals as shown in the following drawing. The resistor leads should be kept as short as possible. See D190-06-001 for details.

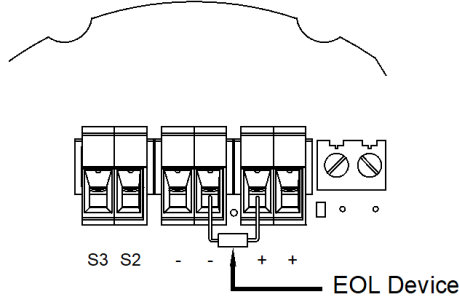

Figure 9: End of Line Resistor placement.

Note: For forward voltage polarity line monitoring the maximum voltage is 4Vdc. For wiring configuration 4 (product option Y) and configuration 6 (product option V) line monitoring requires common negative between each power input. For monitoring voltage, the installer should allow for system cabling and voltage drops

10.2 Custom DC Multi-Stage End Of Line Monitoring

An optional 12-way terminal module is available to enable up to four alarm stages to be activated from three DC voltage output channels. The three alarm stage activation inputs can be independently monitored.

Refer to Schematic D190-06-001, Config. 6.
 Specify Product option 'V' when ordering.
 Spare part code for field installation: SP78-0001

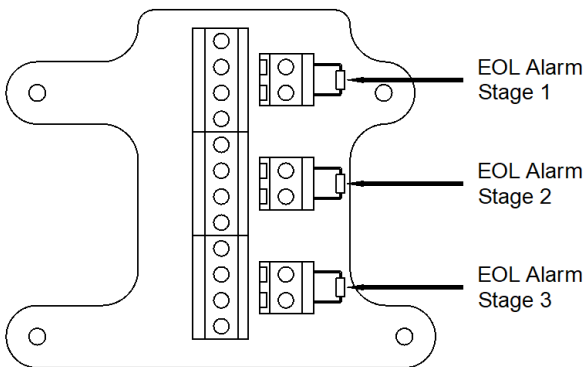

Figure 10: End of Line Resistor placement – Optional 12-Way Terminal Module.

11) Maintenance, Overhaul and Repair

Maintenance, repair and overhaul of the equipment should only be carried out by suitably qualified personnel in accordance with the current relevant standards:

For ATEX/IECEX or UKEx:

EN60079-19/IEC60079-19
 Explosive atmospheres – Equipment repair, overhaul and reclamation

EN 60079-17/IEC60079-17
 Explosive atmospheres – Electrical installations inspection and maintenance

Units must not be opened while an explosive atmosphere is present.

If opening the unit during maintenance operations, a clean environment must be maintained and any dust layer removed prior to opening the unit.

Potential electrostatic charging hazard – Clean only with a damp cloth.

12) SIL 2 Reliability Data

Reliability and Functional safety IEC/EN61508 which has been assessed and is considered suitable for use in low demand safety function:

1. Random Hardware Failures and Architectural constraints (route 2H).
2. As an unvoted item (i.e. hardware fault tolerance of 0) at SIL 2. The product was assessed against failure modes:
 - Failure respond to an input by sounding sounder.
 - Spurious sound output despite no input.
3. When employing the device in a SIL2 compliant system the user should ensure frequent or continuous automatic monitoring of continuity.

Integrity in respect of failure to function	SIL2 & SIL1
Total Failure rate	0.55 pmh
"Hazardous" failure rate (revealed)	0 pmh
"Hazardous" failure rate (unrevealed)	0.55 pmh
"Safe" failure rate (revealed)	0 pmh
"Safe" failure rate (unrevealed)	0
System type	B
Hardware Fault Tolerance	0
Diagnostic Coverage	>80%
PFD (hazardous failure)	2.4×10^{-3}
Proof Test Interval	Up to 1 year

Construction Product Regulation & UKCA Certification

- D1xS1FDC024 is compliant with EN54-3:2001+A1+A2 (Tested to EN54-3:2014+A1:2019)
- Alarm Devices - Sounder for use in fire detection and fire alarm systems installed in and around buildings
- IP Rating: IP33C compliant to EN54-3 (Type 4 / 4X / 3R / 13, IP66/IP67 independently tested to EN60529:1991)
- Type B Product, For Indoor & Outdoor use
- Observe precautions for handling electrostatic sensitive devices
- Operating Temperature for EN54-3: -25°C to +70°C
- Cable Glands: To order, or customer supplied – Must be suitably sealed and meet minimum IP33C for EN54-3 applications
- Maintenance: None
- Mounting: Units to be mounted using at least 2 of the 3-off ø7mm fixing holes in mounting bracket.
- Volume Must be set to Maximum
- Only Stage 1 operation is compliant to EN54-3

- Order Code: D1xS1FDC024***A1R / D1xS1FDC024***A1G
- Voltage Range: 11.5-54Vdc
- Nominal Voltage: 24Vdc
- Max Current: 221mA @ 12Vdc
- Max Power : 2.7W
- DOP: DP-2831-CPR-F4858
- UKCA Cert : 0832-UKCA-CPR-F1782
- EU Cert : 2831-CPR-F4858



Approved Tones for EN54-3 Applications:

- (Continuous Tone) 1000Hz PFEER Toxic Gas **Tone 1**
- (Fainting Tone) 1200/500Hz @ 1Hz **Tone 2**
- (Alternating Tone) 544Hz(100mS)/440Hz (400mS) **Tone 5**
- (Rising Tone) 500/1200Hz @ 0.26Hz (3.3s on, 0.5s off) **Tone 8**
- (Alternating Tone) 554/440Hz @ 1Hz Alternating **Tone 40**
- (Alternating Tone) 800/1000Hz @ 2Hz Alternating **Tone 44**
- (Sweeping Tone) 800/1000Hz @ 1Hz Sweeping **Tone 53**

D1xS1FDC024 @ 1m														
Angle	Horizontal Sound Output Max Voltage (54 Vdc) LAFmax,T dB(A)							Horizontal Sound Output Min Voltage (11.5 Vdc) LAFmax,T dB(A)						
	Tone 1	Tone 2	Tone 5	Tone 8	Tone 40	Tone 44	Tone 53	Tone 1	Tone 2	Tone 5	Tone 8	Tone 40	Tone 44	Tone 53
15°	101.5	101.2	98.5	101.7	99.9	101.2	100.6	98.2	98.0	95.4	98.6	96.6	97.8	97.4
45°	102.0	108.1	103.0	109.8	104.1	105.9	106.4	98.6	104.9	99.9	106.8	100.9	105.3	103.2
75°	112.8	112.2	105.8	112.7	106.5	112.4	112.6	109.5	108.9	103.0	109.6	103.6	109.3	109.2
105°	111.6	112.0	105.6	112.3	106.5	111.9	112.4	109.0	108.7	102.8	109.2	103.6	108.8	109.8
135°	103.2	107.0	102.0	107.8	103.6	106.6	107.7	99.6	103.7	99.0	104.7	100.5	103.3	104.0
165°	100.0	100.9	98.5	101.3	99.9	100.0	101.1	96.7	97.7	97.0	98.3	96.7	96.7	97.9
Angle	Vertical Sound Output Max Voltage (54 Vdc) LAFmax,T dB(A)							Vertical Sound Output Min Voltage (11.5 Vdc) LAFmax,T dB(A)						
	Tone 1	Tone 2	Tone 5	Tone 8	Tone 40	Tone 44	Tone 53	Tone 1	Tone 2	Tone 5	Tone 8	Tone 40	Tone 44	Tone 53
15°	101.1	101.2	98.5	101.7	99.8	100.7	100.7	97.9	98.1	95.4	98.8	96.6	97.4	97.5
45°	101.8	108.0	103.2	109.5	104.4	104.1	106.3	98.7	105	100.1	106.8	101.1	102.7	103.1
75°	112.7	112.1	105.8	112.7	106.5	111.9	112.7	109.7	109.1	103.0	109.5	103.6	109.2	109.5
105°	112.2	111.9	105.6	112.3	106.6	112.0	112.4	109.1	108.8	102.8	109.2	103.7	108.9	109.2
135°	103.1	106.9	101.9	107.8	103.5	106.4	107.6	99.9	103.7	98.9	104.7	100.4	103.2	104.4
165°	99.7	100.8	98.6	101.6	100.0	100.0	101.1	96.6	97.7	95.3	98.4	96.8	96.9	98.0



· All models are approved for use as Audible Signal Appliance for use as General Signaling: UL464A & CSA C22.2 No 205-17

· Type 4 / 4X / 3R / 13, IP66

· -55°C to +85°C / -67°C to +176°F

General Signaling Canada:

D1xS1-AC230-A: -55°C to +40°C / -67°F to +104°F

D1xS1-DC024-A, D1xS1-DC024-S: -55°C to +85°C / -67°F to +185°F

· To maintain Ingress Protection, cable entries must be fitted with suitably rated cable glands or stopping plugs

· EOL Monitoring (DC Only): End of Line Devices may be fitted between the +ve & -ve terminals of the PCBA. Please ensure that the device legs meet the wire size range stated for the connection terminals and are fitted correctly in order to avoid a short. Refer to the compatible control panel specification for EOL device values and ratings

Model	Nominal Voltage	Voltage Range	P1 Nominal Operating Current [#]	P2 Nominal Operating Current [#]	P3 Nominal Operating Current [#]	P1 Max Operating RMS [*]	P2 Max Operating RMS [*]	P3 Max Operating RMS [*]
D1xS1-DC024-A	12V dc	11.5 - 54V dc	221mA	-	-	221mA	-	-
	24V dc		185mA	-	-			
	48V dc		115mA	-	-			
D1xS1-AC230-A	115V ac	100- 240V ac 50/60Hz	73mA	-	-	80mA	-	-
	230V ac		48mA	-	-			

*Max Operating current for worst-case input voltage; Nominal current at nominal voltage and Tone 12

Table 4: UL General Signaling Electrical ratings

FIRE INSTRUCTION & SERVICE MANUAL
D1xS Sounder UL464 / CAN/ULC-S525 Fire
Models: D1xS1-DC024-A. D1xS2-DC024-A,
D1xS1-DC024-S. D1xS2-DC024-S,



Attention: Installation must be carried out by an electrician in compliance with the National Electrical Code, NFPA 70, and the National Fire Alarm Signaling Code, NFPA 72 or CSA 22.1 Canadian Electrical Code, Part I, Safety Standard for Electrical Installations, Section 32 / L'installation doit exclusivement être réalisée par du personnel qualifié, conformément au code national d'électricité américain, NFPA 70, et le code national d'alarme incendie et de signalisation NFPA 72 ou CSA 22.1 Code canadien de l'électricité, première partie, norme de sécurité relative aux installations électriques, Section 32



Attention: Disconnect from power source before installation or service to prevent electric shock / Débranchez-le de la source d'alimentation avant l'installation ou l'entretien pour éviter tout choc électrique.



Attention: Do not paint / Ne pas Peinturer

- 55°C to +85°C / -67°F to +185°F
- Units can be mounted using at least 2 of the 3-off \varnothing 7mm holes in the mounting bracket.
- D1xS1RDC024-A & D1xS1RDC024-S are approved for use as an audible signal appliance for fire alarm use – Public Mode (UL464 & CAN/ULC-S525) and produce a minimum sound pressure level of US: 81.62dB(A); CA: 84.8dB(A) at 10 feet, (figures @ worst case 11.5Vdc).
- D1xS1RDC024-A & D1xS1RDC024-S produce a minimum sound pressure level of US: 83.4dB(A); CA: 86.4dB(A) at 10 feet (@24Vdc)
- D1xS1FDC024-A & D1xS1FDC024-S are approved for use as an audible signal appliance for fire alarm use – Public Mode (UL464 & CAN/ULC-S525) and produce a minimum sound pressure level of: US: 92.06dB(A); CA: 98.2dB(A) at 10 feet, (figures @ worst case 11.5Vdc).
- D1xS1FDC024-A & D1xS1FDC024-S produce a minimum sound pressure level of: US: 94.62dB(A); CA: 100.9dB(A) at 10 feet (@24Vdc)
- D1xS2FDC024-A & D1xS1FDC024-S are approved for use as an audible signal appliance for fire alarm use – Public Mode (UL464 & CAN/ULC-S525) and produce a minimum sound pressure level of P1: US: 93.56dB(A) / P2: US: 94.9dB(A); CA: 101.6dB(A) / P3: US: 95.51dB(A); CA: 101.8dB(A) at 10 feet, (figures @ worst case 11.5Vdc).
- D1xS2FDC024-A & D1xS2FDC024-S produce a minimum sound pressure level of P1: US: 95.64dB(A) / P2: US: 98.42dB(A); CA: 105.2dB(A) / P3: US: 102.7dB(A); CA: 109.4dB(A) at 10 feet (@24Vdc)
- D1xS2HDC024-A & D1xS2HDC024-S are approved for use as an audible signal appliance for fire alarm use – Public Mode (UL464 & CAN/ULC-S525) and produce a minimum sound pressure level of P2: US: 95.51dB(A); CA: 103.8dB(A) / P3: US: 96.24dB(A); CA: 105dB(A) at 10 feet, (figures @ worst case 11.5Vdc).
- D1xS2HDC024-A & D1xS2HDC024-S produce a minimum sound pressure level of P2: US: 100.2dB(A); CA: 108.5dB(A) / P3: US: 103.5dB(A); CA: 111.6dB(A) at 10 feet (@24Vdc)
- For Fire Alarm applications, the Sounder Volume must be at the highest setting, (see volume control section). For fire alarm use, Tone 12 as shown below must be selected:

Stage 1 Set DIP SW 1 Tone No.	Tone Description	Tone Visual	Stage 1 & 2 DIP SW 1/2 Settings 1 2 3 4 5 6	Stage 3 Set DIP SW 1 (S3)	Stage 4 Set DIP SW 1 (S2 + S3)
12	1000Hz(0.5s on, 0.5s off)x3 + 1s gap ISO 8201 Temporal Pattern		1 1 0 1 0 0	1	8

- Connection Terminals: Pluggable
 AC: 1.0 - 2.5mm² / AWG18 - AWG12
 DC: 0.2 - 2.5mm² / AWG24 - AWG12
- Terminal Tightening torque 0.4Nm
- To maintain Ingress Protection, cable entries must be fitted with suitably rated cable glands or stopping plugs
- Units can be located indoor or outdoor wet use, wall or ceiling mounted and there are no limitations on orientation
- Factory finishes are not intended to be modified

Surge Current Ratings for use in fire alarm systems

Model	Nominal Voltage	Voltage Range	Initial Peak	Initial RMS
D1xS1-DC024-A	24V dc	11.5 - 54V dc	P1: 1312mA	P1: 159mA
D1xS1-DC024-S		20 - 28V dc	P1: 1312mA	P1: 159mA
D1xS2-DC024-A		11.5 - 54V dc	P2: 1005mA / P3: 1267mA	P2: 286mA / P3: 553mA
D1xS2-DC024-S		20 - 28V dc	P2: 1005mA / P3: 1267mA	P2: 286mA / P3: 553mA

FIRE INSTRUCTION & SERVICE MANUAL
D1xS Sounder UL464 / CAN/ULC-S525 Fire
Models: D1xS1-DC024-A. D1xS2-DC024-A,
D1xS1-DC024-S. D1xS2-DC024-S,

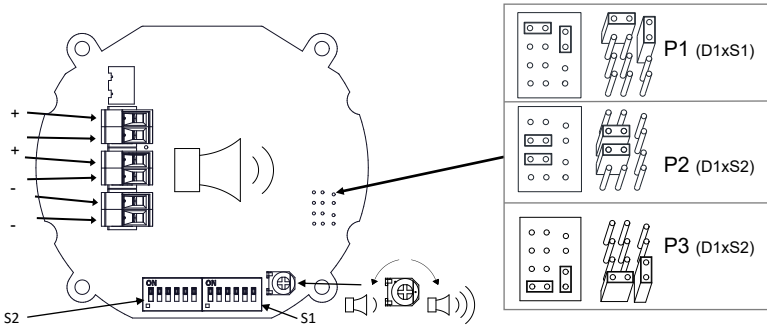

D1xS1FDC024-A & D1xS1FDC024-S Sounder Directional Characteristics for Canadian Fire CAN/ULC-S525

OSPL	Horizontal Axis	Vertical Axis
-3dB(A)	+39° / -41°	+38° / -41°
-6dB(A)	+45° / -47°	+64° / -69°

D1xS1RDC024-A & D1xS1RDC024-S Sounder Directional Characteristics for Canadian Fire CAN/ULC-S525

OSPL	Horizontal Axis	Vertical Axis
-3dB(A)	+42° / -41°	+42° / -41°
-6dB(A)	+48° / -48°	+48° / -49°

D1xS2FDC024-A & D1xS2FDC024-S Sounder Directional Characteristics for Canadian Fire CAN/ULC-S525 (P3)

OSPL	Horizontal Axis	Vertical Axis
-3dB(A)	+46° / -48°	+46° / -47°
-6dB(A)	+52° / -54°	+52° / -53°

D1xS2HDC024-A & D1xS2HDC024-S Sounder Directional Characteristics for Canadian Fire CAN/ULC-S525 (P3)

OSPL	Horizontal Axis	Vertical Axis
-3dB(A)	+16° / -21°	+15° / -21°
-6dB(A)	+40° / -44°	+40° / -44°

Stage 1 Set DIP SW 1 Tone No.	Tone Description	Tone Visual	Stage 1 & 2 DIP SW 1/2 Settings 1 2 3 4 5 6	Stage 3 Set DIP SW 1 (S3)	Stage 4 Set DIP SW 1 (S2 + S3)
1	1000Hz PFEER Toxic Gas		0 0 0 0 0	2	44
2	1200/500Hz @ 1Hz DIN /PFEER P.T.A.P.		1 0 0 0 0	3	44
3	1000Hz @ 0.5Hz(1s on, 1soff) PFEER Gen. Alarm		0 1 0 0 0	2	44
4	1.4KHz-1.6KHz 1s, 1.6KHz-1.4KHz 0.5s NF C 48-265		1 1 0 0 0	24	1
5	544Hz(100mS)/440Hz (400mS) NF S 32-001		0 0 1 0 0	19	1
6	1500/500Hz - 0.5s on , 0.5s off, 0.5s on , 0.5s off, 0.5s on , 1.5s off AS4428		1 0 1 0 0	44	1
7	500-1500Hz Sweeping 2 sec on 1 sec off AS4428		0 1 1 0 0	44	1
8	500/1200Hz @ 0.26Hz (3.3son, 0.5s off) Netherlands -		1 1 1 0 0	24	35
9	NEN 2575 1000Hz (1s on, 1s off)x7 + (7s on, 1s off) IMO Code 1a		0 0 0 1 0	34	1
10	1000Hz (1s on, 1s off)x7 + (7s on, 1s off) IMO Code 1a		1 0 0 1 0	34	1
11	420Hz 0.5s on, 0.5s off, 0.5s on , 0.5s off, 0.5s on, 1.5s off ISO 8201 Temporal Pattern		0 1 0 1 0	1	8
12	1000Hz 0.5s on, 0.0.5s on, 0.5s off, 0.5s on , 0.5s off, 0.5s on , 1.5s off ISO 8201 Temporal Pattern		1 1 0 1 0	1	8
13	422/775Hz - 0.85 on, 0.5 off, 0.85 on, 0.5 off, 0.85 on, 1.5 off NFPA - Temporal Coded		0 0 1 1 0	1	8
14	1000/2000Hz @ 1Hz Alternating Singapore		1 0 1 1 0	3	35
15	300Hz Continuous (f=300)		0 1 1 1 0	24	35
16	440Hz Continuous (f=440)		1 1 1 1 0	24	35
17	470Hz Continuous (f=470)		0 0 0 0 1	24	35
18	500Hz Continuous IMO code 2 (Low) (f=500)		1 0 0 0 1	24	35
19	554Hz Continuous (f=554)		0 1 0 0 1	24	35
20	660Hz Continuous (f=660)		1 1 0 0 1	24	35
21	800Hz IMO code 2 (High) (f=800)		0 0 1 0 1	24	35
22	1200Hz Continuous (f=1200)		1 0 1 0 1	24	35
23	2000Hz Continuous (f=2000)		0 1 1 0 1	3	35
24	2400Hz Continuous (f=2400)		1 1 1 0 1	20	35
25	440Hz @0.83Hz (50 cycles/minute) Intermittent (f=440, a=0.6, b=0.6)		0 0 0 1 1	44	8
26	470Hz @0.9Hz - 1.1s Intermittent (f=470, a=0.55, b=0.55)		1 0 0 1 1	44	8
27	470Hz @5Hz - (5 cycles/second) Intermittent (f=470, a=0.1, b=0.1)		0 1 0 1 1	44	8
28	544Hz @ 1.14Hz - 0.875s Intermittent (f=470, a=0.43, b=0.44)		1 1 0 1 1	24	8
29	655Hz @ 0.875Hz Intermittent (f=655, a=0.57, b=0.57)		0 0 1 1 1	44	8
30	660Hz @0.28Hz - 1.8sec on, 1.8sec off Intermittent (f=660, a=1.8, b=1.8)		1 0 1 1 1	24	8
31	660Hz @3.34Hz - 150mS on, 150mS off Intermittent (f=660, a=0.15, b=0.15)		0 1 1 1 1	24	8
32	745Hz @ 1Hz Intermittent (f=745, a=0.5, b=0.5)		1 1 1 1 1	24	8
33	800Hz - 0.25sec on, 1 sec off Intermittent (f=800, a=0.25, b=1)		0 0 0 0 1	24	8
34	800Hz @ 2Hz IMO code 3.a (High) Intermittent (f=800, a=0.25, b=0.25)		1 0 0 0 1	24	8
35	1000Hz @ 1Hz Intermittent (f=1000, a=0.5, b=0.5)		0 1 0 0 1	24	8
36	2400Hz @ 1Hz Intermittent (f=2400, a=0.5, b=0.5)		1 1 0 0 1	24	8
37	2900Hz @ 5Hz Intermittent (f=2900, a=0.1, b=0.1)		0 0 1 0 1	24	8
38	363/518Hz @ 1Hz Alternating (f=363, f1=518, a=0.1)		1 0 1 0 1	8	19
39	450/500Hz @ 2Hz Alternating (f=450, f1=500, a=0.25)		0 1 1 0 1	8	19
40	554/440Hz @ 1Hz Alternating (f=440, f1=554, a=0.5)		1 1 1 0 1	24	19
41	554/440Hz @ 0.625Hz Alternating (f=440, f1=554, a=0.8)		0 0 0 1 1	8	19
42	561/760Hz @0.83Hz (50 cycles/minute) Alternating (f=561, f1=760, a=0.6)		1 0 0 1 1	8	19
43	780/600Hz @ 0.96Hz Alternating (f=600, f1=780, a=0.52)		0 1 0 1 1	8	19
44	800/1000Hz @ 2Hz Alternating (f=800, f1=1000, a=0.25)		1 1 0 1 1	24	19
45	970/800Hz @ 2Hz Alternating (f=800, f1=970, a=0.25)		0 0 1 1 1	8	19
46	800/1000Hz @ 0.875Hz Alternating (f=800, f1=1000, a=0.57)		1 0 1 1 1	24	19
47	2400/2900Hz @ 2Hz Alternating (f=2400, f1=2900, a=0.25)		0 1 1 1 1	24	19
48	500/1200Hz @ 0.3Hz Sweeping (f=500, f1=1200, a=3.34)		1 1 1 1 1	24	12
49	560/1055Hz @ 0.18Hz Sweeping (f=560, f1=1055, a=5.47)		0 0 0 1 1	24	12
50	560/1055Hz @ 3.3Hz Sweeping (f=560, f1=1055, a=0.3)		1 0 0 1 1	24	12
51	600/1250Hz @ 0.125Hz Sweeping (f=600, f1=1250, a=8)		0 1 0 0 1	24	12
52	660/1200Hz @ 1Hz Sweeping (f=660, f1=1200, a=1)		1 1 0 0 1	24	12
53	800/1000Hz @ 1Hz Sweeping (f=800, f1=1000, a=1)		0 0 1 0 1	24	12
54	800/1000Hz @ 7Hz Sweeping (f=800, f1=1000, a=0.14)		1 0 1 0 1	24	12
55	800/1000Hz @ 50Hz Sweeping (f=800, f1=1000, a=0.02)		0 1 1 0 1	24	12
56	2400/2900Hz @ 7Hz Sweeping (f=2400, f1=2900, a=0.14)		1 1 1 0 1	24	12
57	2400/2900Hz @ 1Hz Sweeping (f=2400, f1=2900, a=1)		0 0 1 1 1	24	12
58	2400/2900Hz @ 50Hz Sweeping (f=2400, f1=2900, a=0.02)		1 0 0 1 1	24	12
59	2500/3000Hz @ 2Hz Sweeping (f=2500, f1=3000, a=0.5)		0 1 0 1 1	24	12
60	2500/3000Hz @ 7.7Hz Sweeping (f=2500, f1=3000, a=0.13)		1 1 0 1 1	24	12
61	800Hz Motor Siren (f=800, a=1.6)		0 0 1 1 1	24	12
62	1200Hz Motor Siren (f=1200, a=2)		1 0 1 1 1	24	12
63	2400Hz Motor Siren (f=2400, a=1.7)		0 1 1 1 1	24	12
64	Simulated Bell		1 1 1 1 1	21	12

1	2	3	4	5	6	7	8	9	10
							ISSUE	MOD No.	REASON - INITIAL - DATE
							3	ACN0153	OPTIONS Y & V MONITORING DETAILS RSR - 06/06/2024
							4	ACN0168	OPTION R Added for reverse polarity S2 RNP - 25/02/2025

OPTIONAL LINE MONITORING RESISTOR, CUSTOMER SUPPLIED.
 MINIMUM EOL RESISTOR VALUES
 500Ω MIN AT 2W MIN OR 3.3KΩ MIN AT 0.5W MIN

Single Stage Configuration	Config.: 1a	Two Stage Configuration	Config.: 1b	Three/Four Stage Configuration	Config.: 1c
Line Monitoring Set to positive switching (default)		Common Negative Set to positive switching (default)		Common Negative Set to positive switching (default)	
Stage 1: Apply Power to Stage 1 +ve & Stage 1 -ve		Stage 1: Apply Power to Stage 1 +ve & Common -ve Stage 2: Apply Power to Stage 2 +ve & Common -ve		Stage 1: Apply Power to Stage 1 +ve & Common -ve Stage 2: Apply Power to Stage 2 +ve & Common -ve Stage 3: Apply Power to Stage 3 +ve & Common -ve Stage 4: Apply Power to Stage 2 +ve, Stage 3 +ve & Common -ve	

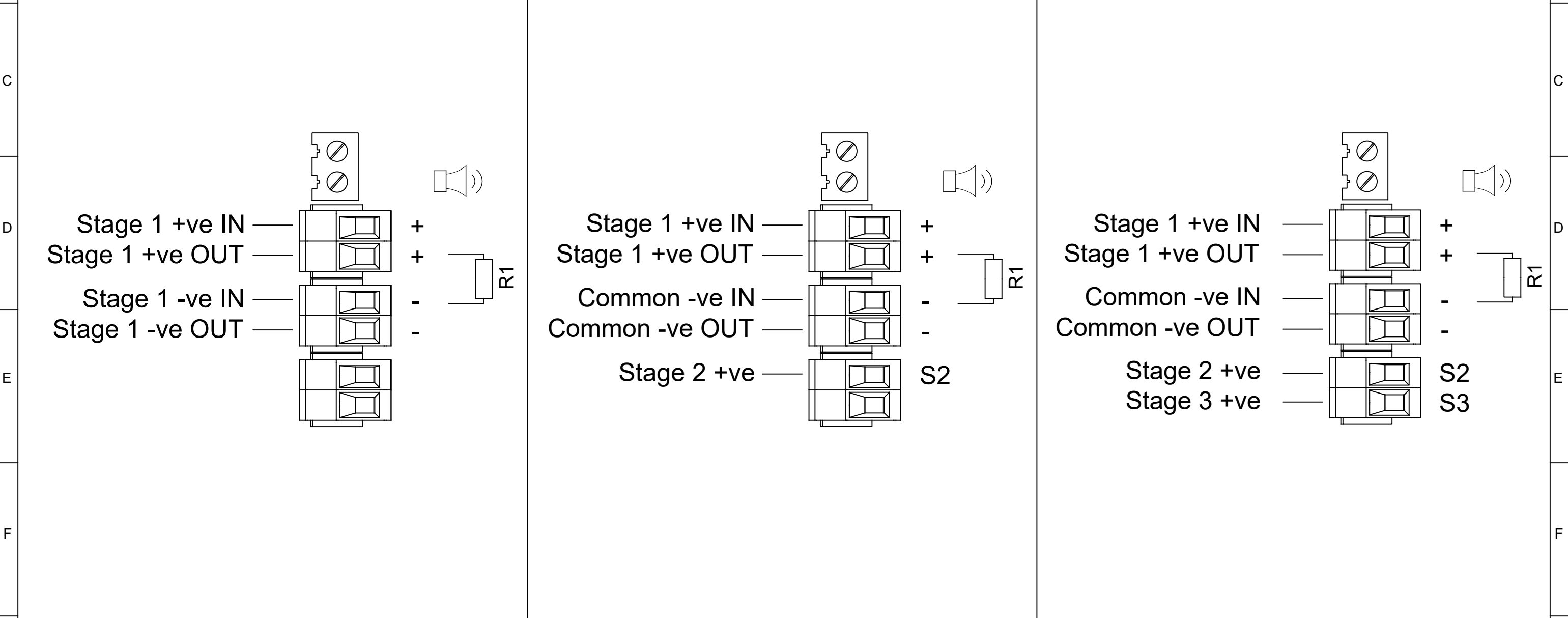

DRAWING TO BS8888:2000 GEOMETRIC TOLERANCES TO ISO1101:1983 LINEAR DIMENSIONAL TOLS ANGULAR DIMENSIONAL TOLS	DRAWN	DATE	SURFACE FINISH	WEIGHT (Kg)	THIS DRAWING AND ANY INFORMATION OR DESCRIPTIVE MATTER THEREIN IS COMMUNICATED IN CONFIDENCE AND IS THE COPYRIGHT PROPERTY OF EUROPEAN SAFETY SYSTEMS LTD. NEITHER THE WHOLE OR ANY EXTRACT MAY BE DISCLOSED, LOANED, COPIED OR USED FOR MANUFACTURING OR TENDERING PURPOSES WITHOUT THEIR WRITTEN CONSENT.	 EUROPEAN SAFETY SYSTEMS LTD IMPRESS HOUSE MANSELL ROAD ACTON LONDON W3 7QH WWW.E2S.COM	ALL DIMENSIONS IN MM IF IN DOUBT, ASK - DO NOT SCALE		A3
	R.S.RAIT	19/01/2022					MATERIAL		
	STANDARDS	CHECKED	DATE	ALTERNATIVE MATERIAL			SCALE	SHEET	DRAWING NUMBER
D1x	B.ISARD	19/01/2022			NTS	1 OF 4	D190-06-001		
	APPROVED	DATE							
	R.N.POTTS	19/01/2022							

1	2	3	4	5	6	7	8	9	10
							ISSUE	MOD No.	REASON - INITIAL - DATE
							3	ACN0153	SEE SHEET 1 RSR - 06/06/2024
							4	ACN0168	SEE SHEET 1 RSR - 20/12/2023

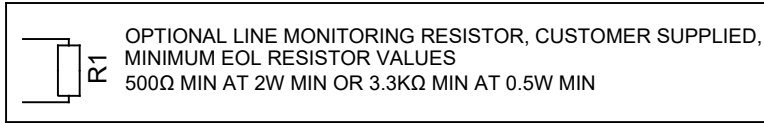

Three/Four Stages. Voltage Free 2nd, 3rd & 4th Stage Activation Configuration				Config.: 2	Two Stage Configuration				Config.: 3
Common Positive Customer Set H1 & H2 to Negative Switching (See Below)				Independent Stage Input Reverse Polarity Stage Monitoring					
Stage 1: Apply Power to Common +ve & Stage 1 -ve Stage 2: Apply Power to Common +ve & Stage 1 -ve & connect Stage 2 -ve to Stage 1 -ve Stage 3: Apply Power to Common +ve & Stage 1 -ve & connect Stage 3 -ve to Stage 1 -ve Stage 4: Apply Power to Common +ve & Stage 1 -ve & connect Stage 2 -ve & Stage 3 -ve to Stage 1 -ve				Stage 1: Apply Power to Stage 1 +ve & Stage 1 -ve Stage 2: Apply Power to Stage 1 +ve & Stage 1 -ve & connect Stage 2 -ve to Stage 1 -ve					

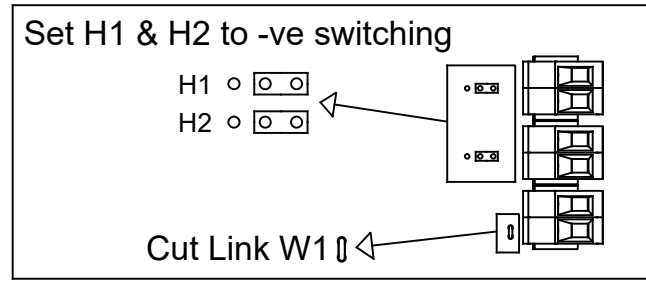
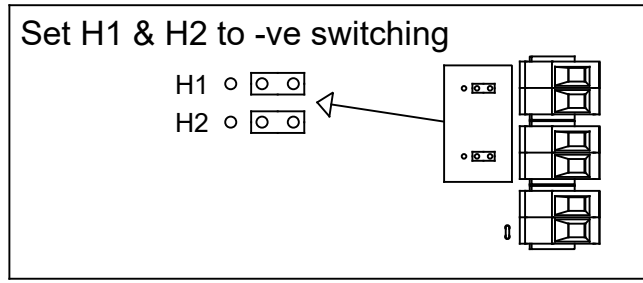
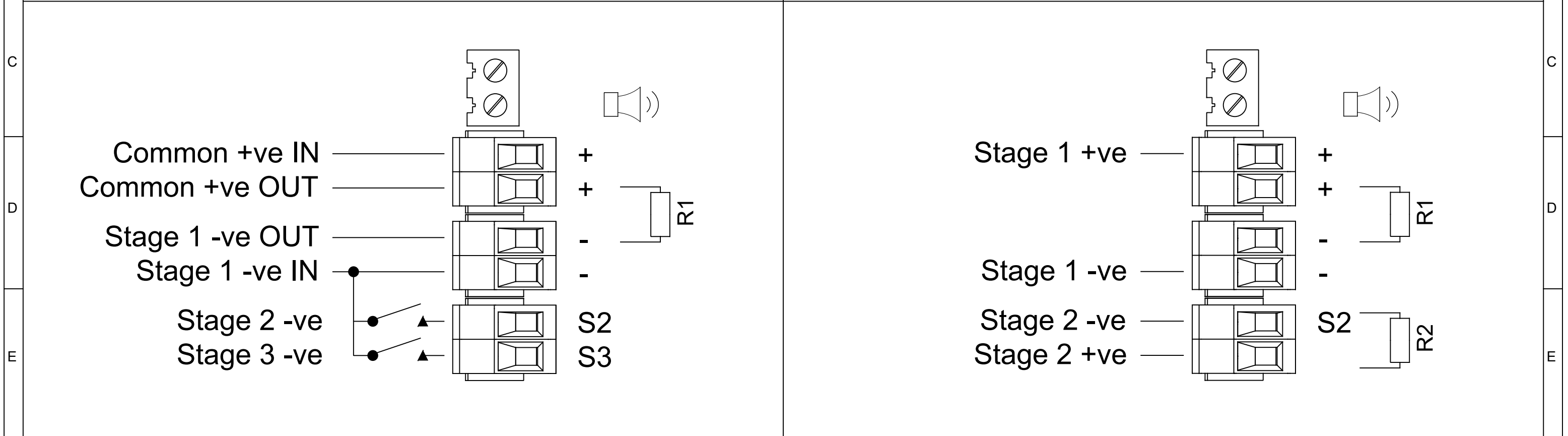

DRAWING TO BS8888:2000 GEOMETRIC TOLERANCES TO ISO1101:1983 LINEAR DIMENSIONAL TOLS ANGULAR DIMENSIONAL TOLS	DRAWN	DATE	SURFACE FINISH	WEIGHT (Kg)	THIS DRAWING AND ANY INFORMATION OR DESCRIPTIVE MATTER THEREIN IS COMMUNICATED IN CONFIDENCE AND IS THE COPYRIGHT PROPERTY OF EUROPEAN SAFETY SYSTEMS LTD. NEITHER THE WHOLE OR ANY EXTRACT MAY BE DISCLOSED, LOANED, COPIED OR USED FOR MANUFACTURING OR TENDERING PURPOSES WITHOUT THEIR WRITTEN CONSENT.	 EUROPEAN SAFETY SYSTEMS LTD IMPRESS HOUSE MANSELL ROAD ACTON LONDON W3 7QH WWW.E2S.COM	ALL DIMENSIONS IN MM IF IN DOUBT, ASK - DO NOT SCALE		 A3		
	CHECKED	DATE	MATERIAL				TITLE D1xS1 / D1xS2 / GNExS1 / GNExS2 / STExS1 / STExS2 DC SOUNDER WIRING DIAGRAMS				
	STANDARDS	APPROVED	DATE	ALTERNATIVE MATERIAL			SCALE	SHEET	DRAWING NUMBER		
	D1x	R.N.POTTS	19/01/2022				NTS	2 OF 4	D190-06-001		

1	2	3	4	5	6	7	8	9	10
							ISSUE	MOD No.	REASON - INITIAL - DATE
							3	ACN0153	SEE SHEET 1 RSR - 06/06/2024
							4	ACN0168	SEE SHEET 1 RSR - 20/12/2023

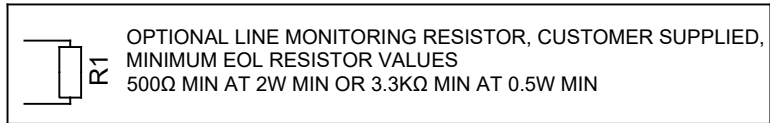

Two Stage Configuration		Config.: 4	Two/Three Stage Voltage Free Activation Configuration		Config.: 5	Three/Four Stage Configuration		Config.: 6
Independent power input for alarm stage activation. Line monitoring available for Stage 1 & 2 alarm stage. Line monitoring requires common negative between each power input. Line monitoring maximum voltage: 4Vdc. Not to be used for reverse polarity line monitoring.			Customer Set H1 & H2 to Negative Switching (See Below)			Independent power input for alarm stage activation. Line monitoring available for Stage 1, 2 & 3 alarm stage. Line monitoring requires common negative between each power input. Line monitoring maximum voltage: 4Vdc. Not to be used for reverse polarity line monitoring.		

Stage 1: Apply Power to Stage 1 +ve & Stage 1 -ve Stage 2: Apply Power to Stage 2 +ve & Stage 2 -ve		Power: +ve & -ve Stage 1: Connect Stage 1 -ve to Common -ve Stage 2: Connect Stage 2 -ve to Common -ve Stage 3: Connect both Stage 1 -ve & Stage 2 -ve to Common -ve		Stage 1: Apply Power to Stage 1 +ve & Stage 1 -ve Stage 2: Apply Power to Stage 2 +ve & Stage 2 -ve Stage 3: Apply Power to Stage 3 +ve & Stage 3 -ve Stage 4: Apply Power to Stage 2 +ve & Stage 2 -ve & Apply Power to Stage 3 +ve & Stage 3 -ve	
--------------------------------------------------------------------------------------------------------	--	-------------------------------------------------------------------------------------------------------------------------------------------------------------------------------	--	-------------------------------------------------------------------------------------------------------------------------------------------------------------------------------------------------------------------------------------------------------------	--

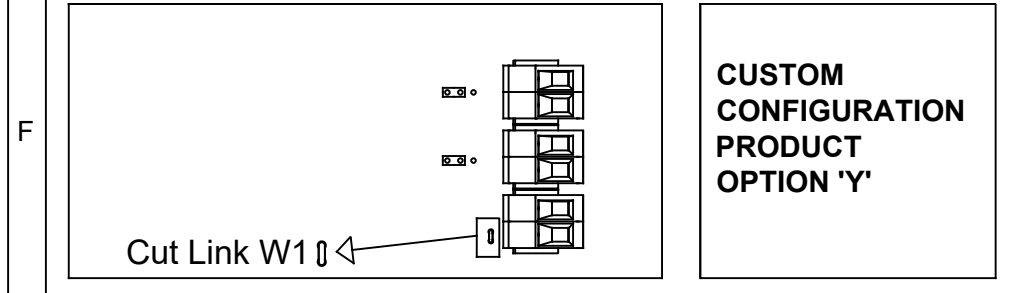
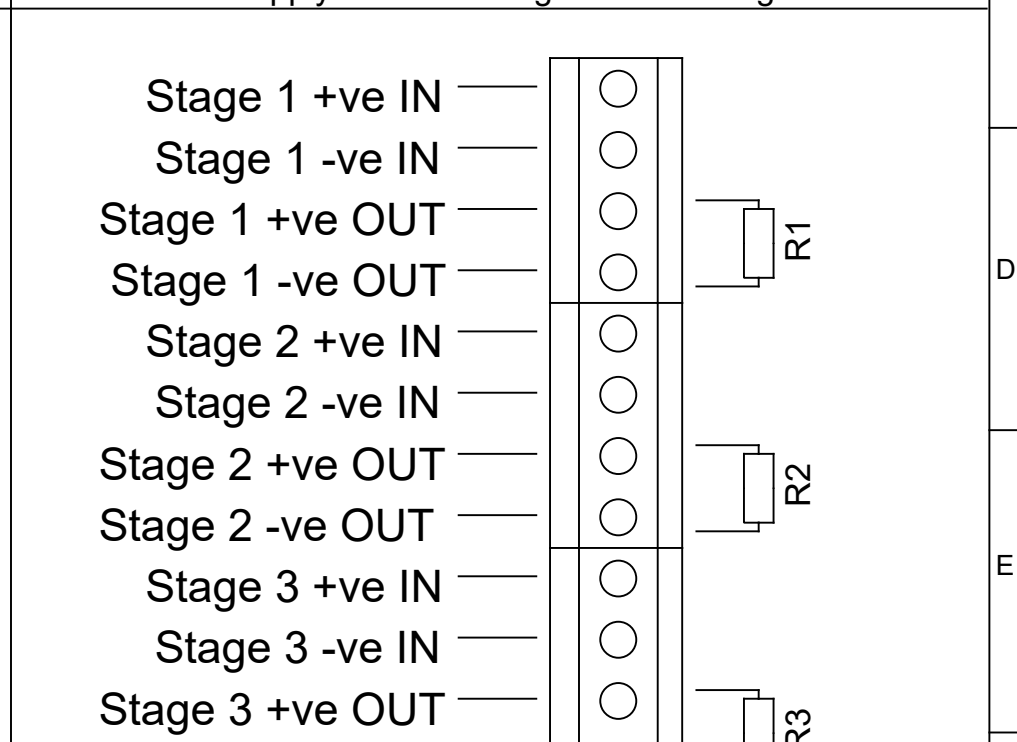
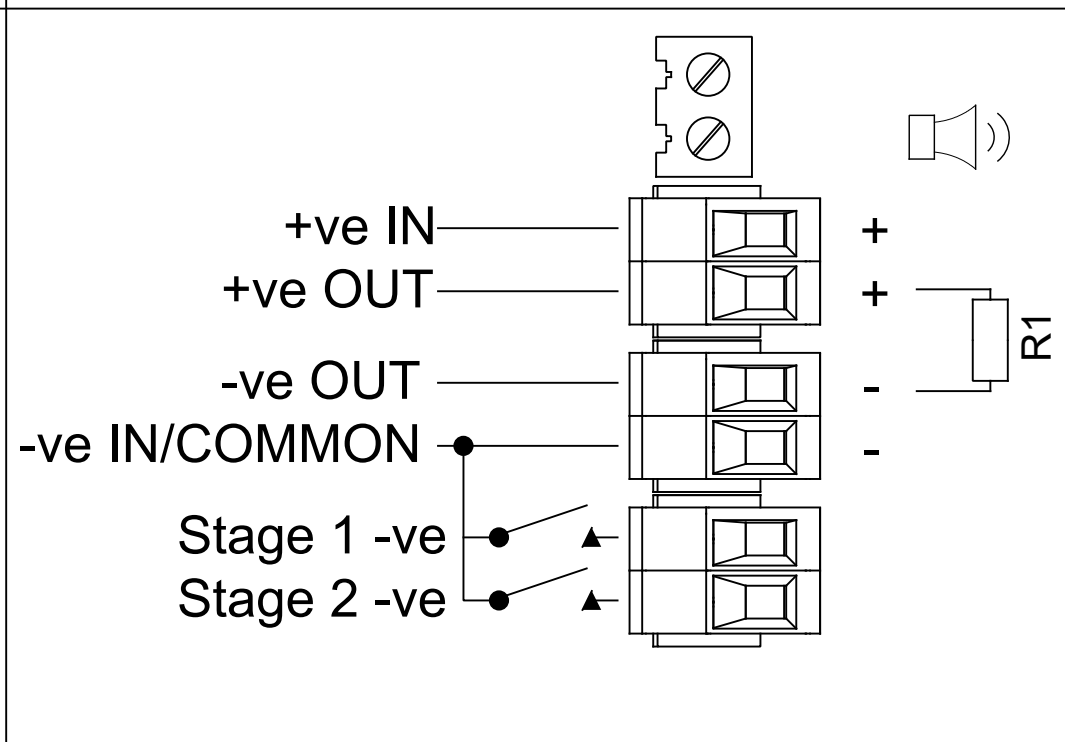
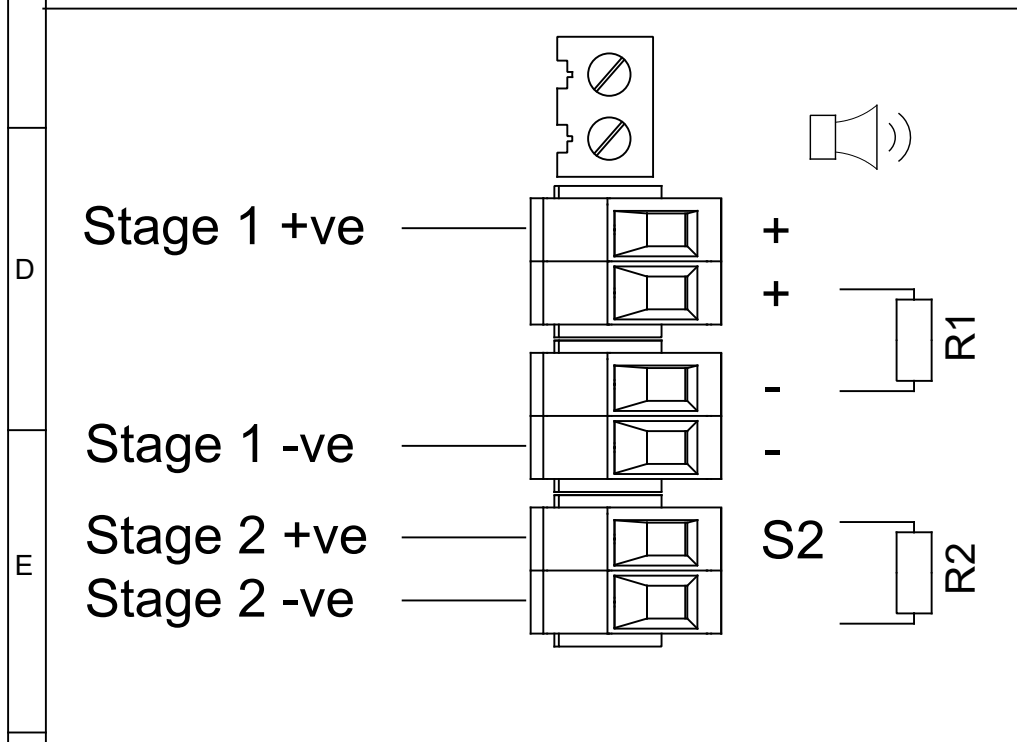

CUSTOM CONFIGURATION PRODUCT OPTION 'Y'

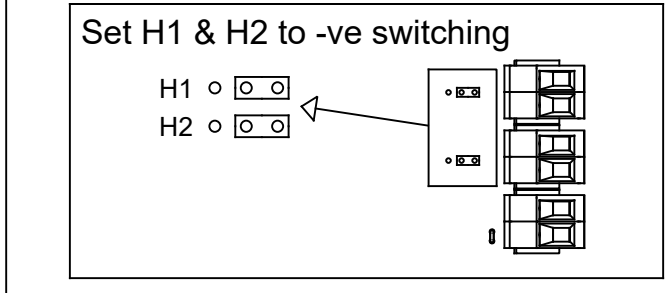

CUSTOM CONFIGURATION PRODUCT OPTION 'K'

(CONFIGURATION SHOWS OPTIONAL ADDITIONAL TERMINAL PCBA - PRODUCT OPTION 'V')

DRAWING TO BS8888:2000 GEOMETRIC TOLERANCES TO ISO1101:1983 LINEAR DIMENSIONAL TOLS ANGULAR DIMENSIONAL TOLS	DRAWN	DATE	SURFACE FINISH	WEIGHT (Kg)	THIS DRAWING AND ANY INFORMATION OR DESCRIPTIVE MATTER THEREIN IS COMMUNICATED IN CONFIDENCE AND IS THE COPYRIGHT PROPERTY OF EUROPEAN SAFETY SYSTEMS LTD. NEITHER THE WHOLE OR ANY EXTRACT MAY BE DISCLOSED, LOANED, COPIED OR USED FOR MANUFACTURING OR TENDERING PURPOSES WITHOUT THEIR WRITTEN CONSENT.	 EUROPEAN SAFETY SYSTEMS LTD IMPRESS HOUSE MANSELL ROAD ACTON LONDON W3 7QH WWW.E2S.COM	ALL DIMENSIONS IN MM IF IN DOUBT, ASK - DO NOT SCALE		 A3		
	CHECKED	DATE	MATERIAL				TITLE D1xS1 / D1xS2 / GNExS1 / GNExS2 / STExS1 / STExS2 DC SOUNDER WIRING DIAGRAMS				
	STANDARDS	APPROVED	DATE	ALTERNATIVE MATERIAL			SCALE	SHEET	DRAWING NUMBER		
	D1x	R.N.POTTS	19/01/2022				NTS	3 OF 4	D190-06-001		

1	2	3	4	5	6	7	8	9	10
							ISSUE	MOD No.	REASON - INITIAL - DATE
							3	ACN0153	SEE SHEET 1 RSR - 06/06/2024
							4	ACN0168	SEE SHEET 1 RSR - 20/12/2023

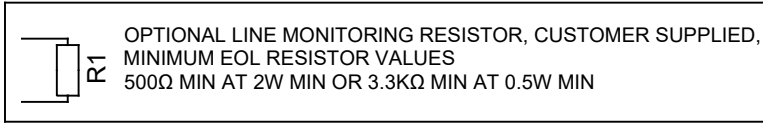

Two Stage Reverse Stage 2 Activation Configuration Config.: 7

Stage 1 power input for alarm stage activation.
Stage 2 Reverse polarity activation.

Line monitoring maximum voltage: 4Vdc.
Not to be used for reverse polarity line monitoring.

Stage 1: Apply Power to Stage 1 +ve & Stage 1 -ve
Stage 2: Apply Reverse Polarity Power to Stage 1 +ve & Stage 1 -ve



DRAWING TO BS8888:2000 GEOMETRIC TOLERANCES TO ISO1101:1983 LINEAR DIMENSIONAL TOLS ANGULAR DIMENSIONAL TOLS	DRAWN R.S.RAIT	DATE 19/01/2022	SURFACE FINISH	WEIGHT (Kg)	THIS DRAWING AND ANY INFORMATION OR DESCRIPTIVE MATTER THEREIN IS COMMUNICATED IN CONFIDENCE AND IS THE COPYRIGHT PROPERTY OF EUROPEAN SAFETY SYSTEMS LTD. NEITHER THE WHOLE OR ANY EXTRACT MAY BE DISCLOSED, LOANED, COPIED OR USED FOR MANUFACTURING OR TENDERING PURPOSES WITHOUT THEIR WRITTEN CONSENT. © EUROPEAN SAFETY SYSTEMS LTD. AS PER LATEST DATE OF ISSUE SHOWN ABOVE	 EUROPEAN SAFETY SYSTEMS LTD IMPRESS HOUSE MANSELL ROAD ACTON LONDON W3 7QH WWW.E2S.COM	ALL DIMENSIONS IN MM IF IN DOUBT, ASK - DO NOT SCALE			A3
	CHECKED B.ISARD	DATE 19/01/2022	MATERIAL				TITLE D1xS1 / D1xS2 / GNExS1 / GNExS2 / STExS1 / STExS2 DC SOUNDER WIRING DIAGRAMS			
	STANDARDS D1x	APPROVED R.N.POTTS	DATE 19/01/2022	ALTERNATIVE MATERIAL			SCALE NTS	SHEET 4 OF 4	DRAWING NUMBER D190-06-001	

SWITCHES FOR STAGE OPERATION
 CUSTOMER SUPPLIED

Single Stage Configuration	Config.: 1a	Three/Four Stage Configuration	Config.: 1b	Two Stage Voltage Free Activation Configuration	Config.: 2	
Stage 1: Apply Power to Stage 1 Live & Stage 1 Neutral		Stage 1: Apply Power to Live & Neutral Stage 2: Apply Power to Live & Neutral & connect Stage 2 to Common Stage 3: Apply Power to Live & Neutral & connect Stage 3 to Common Stage 4: Apply Power to Live & Neutral & connect both Stage 2 & Stage 3 to Common		Power: Live & Neutral Stage 1: Connect Stage 1 to Common Stage 2: Connect Stage 2 to Common Stage 3: Connect both Stage 1 & Stage 2 to Common		

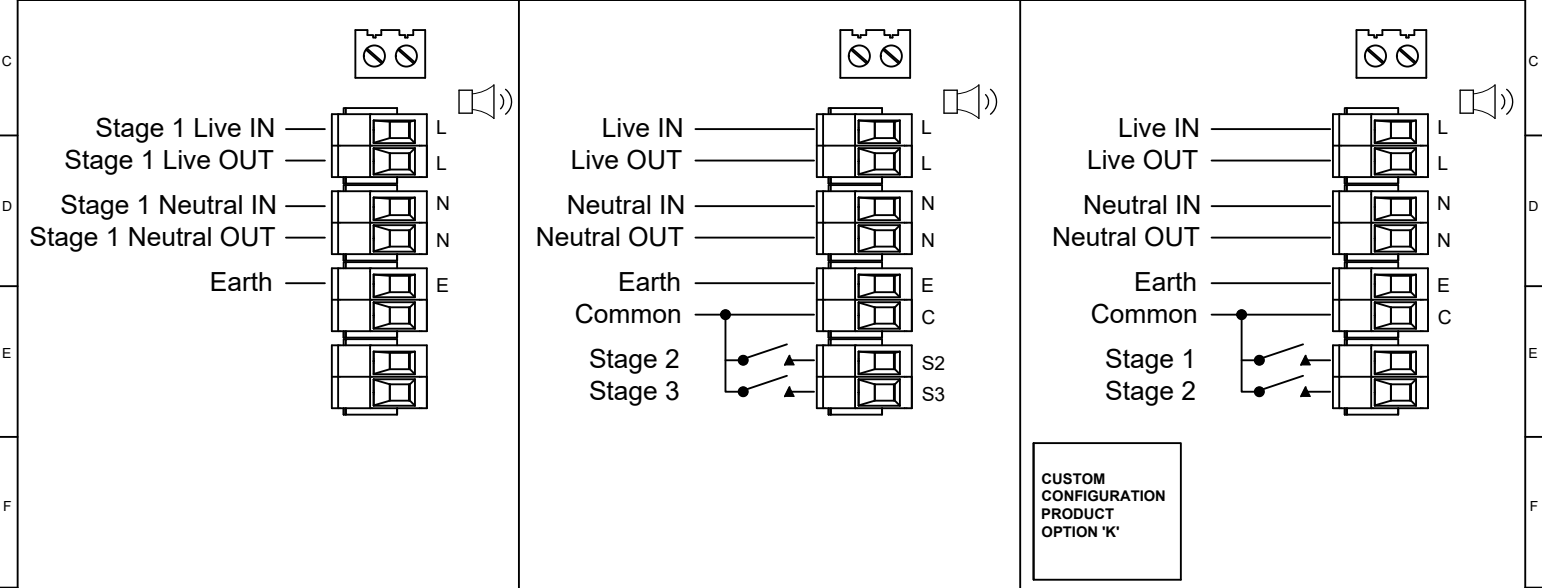

**CUSTOM CONFIGURATION
PRODUCT
OPTION 'K'**

DRAWING TO BS8888:2000 GEOMETRIC TOLERANCES TO ISO1101:1983 LINEAR DIMENSIONAL TOLS ANGULAR DIMENSIONAL TOLS	DRAWN R.S.RAIT	DATE 19/01/2022	SURFACE FINISH	WEIGHT (Kg)	THIS DRAWING AND ANY INFORMATION OR DESCRIPTIVE MATTER THEREIN IS COMMUNICATED IN CONFIDENCE AND IS THE COPYRIGHT PROPERTY OF EUROPEAN SAFETY SYSTEMS LTD. NEITHER THE WHOLE OR ANY EXTRACT MAY BE DISCLOSED, LOANED, COPIED OR USED FOR MANUFACTURING OR TENDERING PURPOSES WITHOUT THEIR WRITTEN CONSENT.	 EUROPEAN SAFETY SYSTEMS LTD IMPRESS HOUSE MANSELL ROAD LONDON W3 7QH WWW.E2S.COM	ALL DIMENSIONS IN MM IF IN DOUBT, ASK - DO NOT SCALE		A3	
STANDARDS D1x	CHECKED B.ISARD	DATE 19/01/2022	MATERIAL	ALTERNATIVE MATERIAL			TITLE D1xS1 / D1xS2 / GNExS1 / GNExS2 / STExS1 / STExS2 AC SOUNDER WIRING DIAGRAMS	SCALE NTS	SHEET 1 OF 1	DRAWING NUMBER D190-06-005
	APPROVED R.N.POTTS	DATE 19/01/2022					© EUROPEAN SAFETY SYSTEMS LTD. AS PER LATEST DATE OF ISSUE SHOWN ABOVE			

EU Declaration of Conformity



Manufacturer: European Safety Systems Ltd.
Impress House, Mansell Road, Acton
London, W3 7QH
United Kingdom

Authorised Representative: E2S Warnsignaltechnik UG
Charlottenstrasse 45-51
72764 Reutlingen
Germany

Equipment Type: D1xS1, D1xS2
D1xL1, D1xL2
D1xC1X05, D1xC1X10, D1xC2X05, D1xC2X10
D1xB2XH1, D1xB2XH2

Directive 2014/34/EU: Equipment and Protective Systems for use in Potentially Explosive Atmospheres (ATEX) - D1xS1, D1xS2, D1xL1, D1xL2, D1xC1X05, D1xC1X10, D1xC2X05 and D1xC2X10 only

Notified Body for EU type Examination (Module B):	UL International Demko A/S Borupvang 5A 2750 Ballerup Denmark
EU-type Examination Certificate (Module B):	DEMKO 19 ATEX 2141X
Notified Body for Quality Assurance Notification / Conformity to EU-type based on quality assurance of the production process (Module D):	Sira Certification Service Notified Body No.: 2813 Unit 6, Hawarden Industrial Park, Hawarden, Deeside, CH5 3US, UK
Quality Assurance Notification (Module D):	SIRA 05 ATEX M342
Provisions fulfilled by the equipment:	II 2G Ex db IIC T6...T3 GB II 2D Ex tb IIIC T82°C...145°C Db
Standards applied:	EN 60079-0:2018 EN 60079-1:2014 EN60079-31:2014

Regulation EU No. 305/2011: Construction Products Regulation (CPR) – D1xS1FDC024***A1R & D1xS1FDC024***A1G only – tones 1, 2, 5, 8, 40, 44, 53 only

Notified Product Certification Body for Certificate of Constancy of Performance or EC Type Examination Certificate and continuous surveillance, assessment and evaluation of factory production control:	BRE Global Assurance (Ireland) Limited Notified Body No.: 2831 DCU Alpha, Old Finglas Road, Glasnevin, Dublin, D11 KXN4
Certificate of Constancy of Performance or EC Type Examination Certificate:	2831-CPR-F4858
Standards applied:	EN 54-3:2001 + A1:2002 + A2:2006

Directive 2014/90/EU: Marine Equipment Directive (MED) – part codes specified below only - D1xS1FDC024***A1R & D1xS1FDC024***A1G only

Notified Body for EU type Examination (Module B) and Conformity to EU-type based on quality assurance of the production process (Module D):	DNV AS Notified Body No.: 0575 DNV Høvik, Norway
EU-Certificate Type Examination (Module B):	MEDB000085K
EU Certificate of Conformity for the Quality Assurance System (Module D):	MEDD00000GV
Standards applied:	EN 54-3:2014 incl. A1: 2019 IEC 60092-504: 2016 IEC 60533: 2015

EU Declaration of Conformity



Directive 2014/30/EU: Electromagnetic Compatibility Directive (EMC)

Standards applied:

EN 61000-6-1:2007
EN 61000-6-2:2005
EN 61000-6-3:2007 / A1:2011 / AC: 2012
EN 61000-6-4:2007 / A1: 2011

Directive 2014/35/EU: Low Voltage Directive (LVD)

Standards applied:

EN 60947-1:2007 + A2:2014

Directive 2011/65/EU: Restriction of the use of certain hazardous substances in electrical and electronic equipment (RoHS)

The product and all the components contained within it are in accordance with the restriction of the use of hazardous substances in electrical and electronic equipment, including amendment by Directive 2015/863/EU.

Regulation (EC) 1907/2006: Registration, Evaluation, Authorisation and Restriction of Chemicals (REACH)

The product and all the components contained within it are free from substances of very high concern.

Other Standards and Regulations

EN 60529:1992+A2:2013 - Degrees of protection provided by enclosures (IP code) – enclosure rated IP66/67

On behalf of European Safety Systems Ltd., I declare that, on the date the equipment accompanied by this declaration is placed on the market, the equipment conforms with all technical and regulatory requirements of the above listed directives, regulations and standards.

This Declaration is issued under the sole responsibility of the manufacturer.

A blue ink signature of Desmond Gayler, written in a cursive style.

Desmond Gayler
Quality Assurance Manager

Document No.: DC-067_Issue_K
Date and Place of Issue: London, 18/03/2024



UKCA Declaration of Conformity



Manufacturer: European Safety Systems Ltd.
Impress House, Mansell Road, Acton
London, W3 7QH
United Kingdom

Equipment Type: D1xS1, D1xS2
D1xL1, D1xL2
D1xC1X05, D1xC1X10, D1xC2X05, D1xC2X10

Directive UKSI 2016:1107 (as amended by UKSI 2019:696) – Schedule 3A, Part 1 : Product or Protective System Intended for use in Potentially Explosive Atmospheres (UKCA)

Notified Body for UK type Examination (Module B):	UL International (UK) Ltd Notified Body No.: 0843 Unit 1-3 Horizon Kingsland Business Park, Wade Road, Basingstoke, Hampshire RG24 8AH UK
UK-type Examination Certificate (Module B):	UL21UKEX2132X
Notified Body for Quality Assurance Notification / Conformity to EU-type based on quality assurance of the production process (Module D):	Sira Certification Service Notified Body No.: 0518 Rake Lane, Eccleston, Chester CH4 9JN, UK
Quality Assurance Notification (Module D):	CSAE 22UKQAN0046
Provisions fulfilled by the equipment:	II 2G Ex db IIC T6...T3 GB II 2D Ex tb IIIC T82°C...145°C Db
Standards applied:	EN 60079-0:2018 EN 60079-1:2014 EN60079-31:2014

Regulation EU No. 305/2011: Construction Products Regulation (CPR) – D1xS1FDC024***A1R & D1xS1FDC024***A1G only – tones 1, 2, 5, 8, 40, 44, 53 only

Notified Product Certification Body for Certificate of Constancy of Performance or EC Type Examination Certificate and continuous surveillance, assessment and evaluation of factory production control:	BRE Global Limited Notified Body No.: 0832 Bucknalls Lane, Garston, Watord, Hertfordshire, UK, WD25 9XX
Certificate of Constancy of Performance or EC Type Examination Certificate:	0832-UKCA-CPR-F1782
Standards applied:	EN 54-3:2001 + A1:2002 + A2:2006

UK Merchant Shipping, Marine Equipment Regulation (MER) 2016 SI 2016/1025– part codes specified below only - D1xS1FDC024***A1R & D1xS1FDC024***A1G only

Notified Body for UK type Examination (Module B) and Conformity to UK-type based on quality assurance of the production process (Module D):	DNV UK Notified Body No.: 0097 DNV, UK
UK-Certificate Type Examination (Module B):	MERB000085K
UK Certificate of Conformity for the Quality Assurance System (Module D):	MERD00000GV
Standards applied:	EN 54-3:2014 incl. A1: 2019 IEC 60092-504: 2016 IEC 60533: 2015

UKCA Declaration of Conformity



Directive 2014/30/EU: Electromagnetic Compatibility Directive (EMC)

Standards applied: EN 61000-6-1:2007
EN 61000-6-2:2005
EN 61000-6-3:2007 / A1:2011 / AC: 2012
EN 61000-6-4:2007 / A1: 2011

Directive 2014/35/EU: Low Voltage Directive (LVD)

Standards applied: EN 60947-1:2007 + A2:2014

Directive 2011/65/EU: Restriction of the use of certain hazardous substances in electrical and electronic equipment (RoHS)

The product and all the components contained within it are in accordance with the restriction of the use of hazardous substances in electrical and electronic equipment, including amendment by Directive 2015/863/EU.

Regulation (EC) 1907/2006: Registration, Evaluation, Authorisation and Restriction of Chemicals (REACH)

The product and all the components contained within it are free from substances of very high concern.

Other Standards and Regulations

EN 60529:1992+A2:2013 - Degrees of protection provided by enclosures (IP code) – enclosure rated IP66/67

On behalf of European Safety Systems Ltd., I declare that, on the date the equipment accompanied by this declaration is placed on the market, the equipment conforms with all technical and regulatory requirements of the above listed directives, regulations and standards.

This Declaration is issued under the sole responsibility of the manufacturer.

A blue ink handwritten signature of Desmond Gayler.

Desmond Gayler
Quality Assurance Manager

Document No.: DC-097_Issue_C
Date and Place of Issue: London, 18/03/2024