

# INSTRUCTION MANUAL

## D2xB1LD2 LED Beacons

### For use in Hazardous Locations

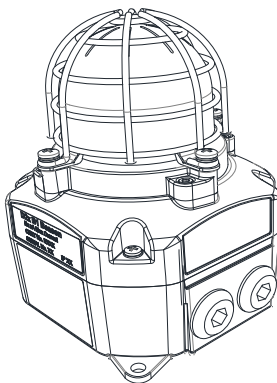

D2xB1LD2

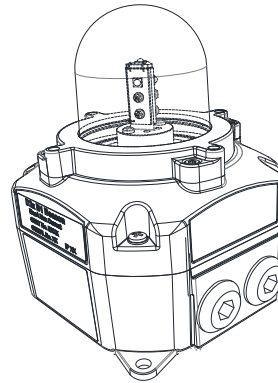

D2xB1LD2-H

## 1) Product Table

Model	Nom. Voltage	Voltage Range	Max Operating Current*
D2xB1LD2DC024	24Vdc	18-54Vdc	346mA
D2xB1LD2DC024 -H#	24vdc	16-33Vdc (Regulated)	346mA
D2xB1LD2AC115	115Vdc	115-120Vac 50/60Hz	102.4mA
D2xB1LD2AC230	230Vdc	220-230Vac 50/60Hz	75mA

\*Max. rms current at worst-case voltage in voltage range.  
 #D2xB1LD2-H public mode beacon (Product Version H). See Section 3.1  
 For detailed current ratings of the device please see Section 15.

Table 1: Electrical Ratings.

## 2) Warnings



- DO NOT OPEN WHEN AN EXPLOSIVE ATMOSPHERE IS PRESENT
- DO NOT OPEN WHEN ENERGISED
- POTENTIAL ELECTROSTATIC CHARGING HAZARD - CLEAN ONLY WITH A DAMP CLOTH

### Avertissement:

- NE PAS OUVRIR UN PRESENCE D'ATMOSPHERE EXPLOSIVE
- NE PAS OUVRIR ENERGIE
- DANGER POTENTIEL CHARGE ÉLECTROSTATIQUE - NETTOYER UNIQUEMENT AVEC UN CHIFFON HUMIDE

## 3.2. ATEX / IECEx / UKEx Ratings

Standards	
EN IEC 60079-0:2018 / IEC60079-0:2017 (Ed 7): Explosive Atmospheres - Equipment. General Requirements	
EN IEC 60079-7:2015 +A1:2018 / IEC 60079-7:2018 (Ed. 5.1): Explosive Atmospheres - Equipment Protection by Increased Safety "e"	
EN 60079-31:2014 / IEC 60079-31:2013 (Ed 2): Explosive Atmospheres - Equipment Dust Ignition Protection by Enclosure "t"	
Ratings	
D2xB1LD2:	Ex ec IIC T4 Gc Ta -40°C to +50°C Ex tc IIIC T75°C Dc Ta -40°C to +50°C

## 3) Rating & Marking Information

### 3.1. Fire Alarm Ratings

All models are approved for use as Visual Appliance for use in Fire Alarm Systems – Private Mode and General Signalling UL1638A.

The D2xB1LD2DC024 Product Version H (D2xB1LD2-H) is certified for use as a public mode visual alarm device in accordance with UL1971 Third Edition and UL1638 Fifth Edition / CAN/ULC-S526 Fourth Edition. For use in public mode the beacon must be without the wire guard or plastic lens cover.

See fire instruction manual D211-00-401-IS-SC-UL

Certificate No. DEMKO 14 ATEX 4786493904X  
IECEx ULD 14.0004X  
UL21UKEX2131X

ATEX Mark, Equipment Group and Category:



II 3G  
II 3D

CE Marking



UKCA Marking



### 3.3. NEC & CEC Ratings

#### NEC & CEC Class / Division Ratings for US / Canada

Standards	
UL 121201-2021 (Ed. 9) CAN/CSA C22.2 No. 213-17 (Ed. 3)	
Ratings	
D2xB1LD2:	Class I Div 2 ABCD T4 Ta -40°C to +50°C Class I Div 2 ABCD T4A Ta -40°C to +40°C Class II Div 2 FG T6 Ta -40°C to +50°C Class III Div 1&2 Ta -40°C to +50°C
Installation must be carried out in compliance with the National Electric Code / Canadian Electric Code	

#### NEC Class / Zone ratings US

Standards	
UL 60079-0 (Ed. 7): Explosive Atmospheres - part 0: Equipment - General Requirements UL 60079-7 (Ed. 5): Explosive Atmospheres - Equipment Protection by Increased Safety "e" UL 60079-31 (Ed. 2) Explosive Atmospheres - Equipment Dust Ignition Protection by Enclosure "t"	
Ratings	
D2xB1LD2:	Class I Zone 2 AEx ec IIC Gc T4 Ta -40°C to +50°C AEx tc IIIB T75°C Dc Ta -40°C to +50°C
Installation must be carried out in compliance with the National Electric Code.	

#### CEC Class / Zone ratings Canada

Standards	
CAN/CSA C22.2 No. 60079-0 (Ed. 4) 02/2019 Explosive Atmospheres - Part 0: Equipment - General Requirements CAN/CSA C22.2 No. 60079-7 (Ed. 2) Explosive Atmospheres - Equipment Protection by Increased Safety "e" CAN/CSA C22.2 No. 60079-31 (Ed. 2) Explosive Atmospheres - Equipment Dust Ignition Protection by Enclosure "t"	
Rating	
D2xB2LD2:	Ex ec IIC Gc X T4 Ta -40°C to +50°C Ex tc IIIC T75°C Dc X Ta -20°C to +50°C
Installation must be carried out in compliance with the Canadian Electric Code	

### 4) Zones, Gas Group, Category and Temperature Classification

When connected to an approved system the D2XB1LD2 LED beacon may be installed in:

Area Classification	
Zone 2	Explosive gas air mixture not likely to occur in normal operation, and if it does, it will only exist for a short time.
Zone 22	Explosive dust air mixture not likely to occur in normal operation, and if it does, it will only exist for a short time.
Gas Groupings	
Group IIA	Propane
Group IIB	Ethylene
Group IIC	Hydrogen and Acetylene
Temperature Classification for Gas Applications	
T1	450°C
T2	300°C
T3	200°C
T4	135°C
Dust Groupings (ATEX / IECEx / UKEX only)	
Group IIIA	Combustible Flyings
Group IIIB	Non-conductive Dust
Group IIIC	Conductive Dust
Maximum Surface Temperature for Dust Applications (ATEX / IECEx / UKEX only)	
D2xB1LD2:	75°C
Equipment Category	
3G / 3D	
Equipment Level Protection	
Gc, Dc	
Ambient Temperature Range	
-40°C to +50°C	
IP Rating	
IP6X to EN/IEC60079-0 IP66 to EN60529 To maintain the ingress protection rating, the two off cable entries must be fitted with suitably rated, certified cable entry and/or blanking devices during installation.	
Type Rating	
Per UL50E / NEMA250: 4 / 4X / 3R / 13	

**Installation must be carried out in compliance with the latest issue of the following standards:**

EN60079-14 / IEC60079-14: Explosive atmospheres - Electrical installations design, selection and erection  
EN60079-10-1 / IEC60079-10-1: Explosive atmospheres - Classification of areas. Explosive gas atmospheres  
EN60079-10-2 / IEC60079-10-2: Explosive atmospheres - Classification of areas. Explosive dust atmospheres

## 5) Special Conditions of Use

Special Condition for safe Use as stated on the Type Examination Certificate DEMKO 14 ATEX 4786493904X / CoC IECEx ULD 14.0004X / UL21UKEX2131X:

When used for a Group III application, the surface of the enclosure may store electrostatic charge and become a source of ignition in applications with a low relative humidity <~30% relative humidity where the surface is relatively free of surface contamination such as dirt, dust, or oil.

Guidance on protection against the risk of ignition due to electrostatic discharge can be found in EN TR50404 and IEC TR60079-32.

End user shall adhere to the manufacturer's installation and instruction when performing housekeeping to avoid the potential for hazardous electrostatic charges during cleaning, by using a damp cloth.

To maintain the ingress protection rating and mode of protection, the cable entries must be fitted with suitably rated, certified cable entry and/or blanking devices during installation.

The equipment shall only be used in an area of at least pollution degree 2, as defined in IEC 60664-1.

## 6) Product Mounting and Access

### 6.1. Location and Mounting

The location of the beacon should be made with due regard to the area over which the warning signal must be visible. It should only be fixed to services that can carry the weight of the unit.

The D2x beacon should be secured to any flat surface using the two 7mm fixing holes in the feet of the base. The 2-off mounting feet supplied with the unit must first be fitted to the base using the 2-off M4 X 12mm countersunk screws provided. Additional feet are available as spare parts if required. The unit can also be pole mounted using the 3/4" NPT Entry in the centre of the base. See Fig. 1a/1b.

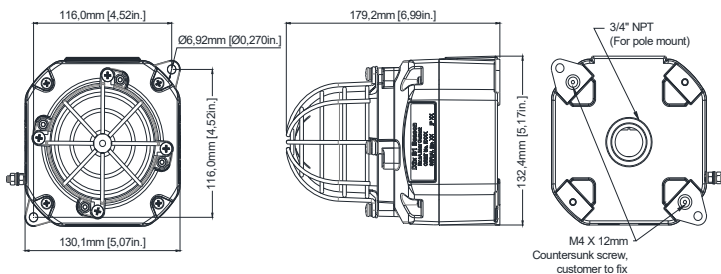

Fig. 1a Fixing Location for General Signaling or Private Mode

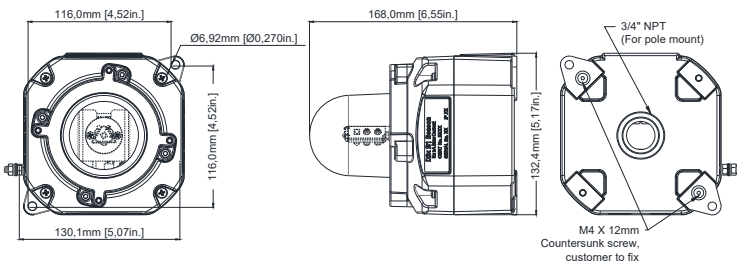

Fig. 1b Fixing Location for Public Mode

### 6.2. Access to the Enclosure



Warning – High voltage may be present, risk of electric shock. DO NOT open when energised, disconnect power before opening.



Warning – Hot surfaces. External surfaces and internal components may be hot after operation, take care when handling the equipment.

To access the enclosure, loosen the four M4 posi pan head screws and withdraw the cover.

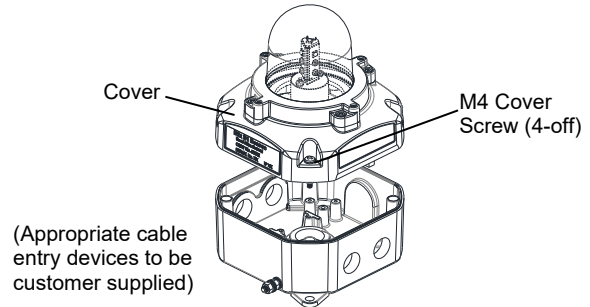

Fig. 2 Accessing the Enclosure.

To replace cover, check that the 'O' ring seal is in place. Carefully push the cover in place. Insert M4 screws with fibre washers and tighten to 3.0Nm torque.

## 7) Selection of Cable, Cable Glands, Blanking Elements & Adapters

When selecting the cable size, consideration must be given to the input current that each unit draws (see Table 1), the number of beacons on the line and the length of the cable runs. The cable size selected must have the necessary capacity to provide the input current to all of the sounders connected to the line.

When selecting the cable size consideration must be given to the voltage drop over the length of the cable run to ensure the min. input voltage at the point of use (voltage range, see section 16)

The voltage drop depends on:

- The total current draw if the devices installed on this cable run
- The wire size and total length of the cable run, determining the total resistance of this cable run
- The minimum output voltage supplied by the power supply

The voltage drop and input voltage at the point of use can be calculated as follows:

$$\text{Total Wire resistance} = \text{Wire resistance} / 1000\text{ft} \times \text{length of cable run} \times 2$$

(length of cable run needs to be multiplied by two to account for two wires going to and from the unit)

$$\text{Total current draw} = \text{Current draw per unit} \times \text{number of units}$$

$$\text{Voltage Drop} = \text{Total current draw} \times \text{Total wire resistance}$$

Minimum output of power supply =  
 Min. voltage at point of use + voltage drop

The entries can be ordered with one of the following options:

2-off M20 x 1.5 thread, 2-off ½" NPT thread & 1-off ¾" NPT thread

For ambient temperatures over +45°C the cable entry temperature may exceed +70°C. Therefore suitable heat resisting cables and cable glands, rated to min. 75°C must be used.

If a high IP (Ingress Protection) rating is required then a suitable sealing washer must be fitted under the cable glands or blanking plugs.

For use in explosive dust atmospheres, a minimum ingress protection rating of IP6X must be maintained.

For use in explosive gas atmospheres, a minimum ingress protection rating of IP54 must be maintained.

NPT plugs should be greased before insertion.

## 8) Cable Connections

Electrical connections are to be made into the terminal blocks on the PCBA located in the enclosure. See section 6 of this manual for access to the enclosure.

Wires having a cross sectional area between 0.5 mm<sup>2</sup> to 2.5mm<sup>2</sup> can be connected to each terminal way. If an input and output wire is required the 2-off Live/Neutral or +/- terminals can be used. If fitting 2-off wires to one terminal way the sum of the 2-off wires must be a maximum cross sectional area of 2.5mm<sup>2</sup>. Strip wires to 8mm. Wires may also be fitted using ferrules. Terminal screws need to be tightened down with a tightening torque of 0.56 Nm / 5 Lb-in. When connecting wires to the terminals great care should be taken to dress the wires so that when the cover is inserted into the chamber the wires do not exert excess pressure on the terminal blocks. This is particularly important when using cables with large cross sectional areas such as 2.5mm<sup>2</sup>.

## 9) AC Wiring

3-off 2-way terminal blocks are provided on the AC beacon for power. There are 2-off Live, 2-off Neutral and 2-off Earth terminals in total.

For further wiring schematics refer to document D211-06-401

## 9.1. PCBA Terminals

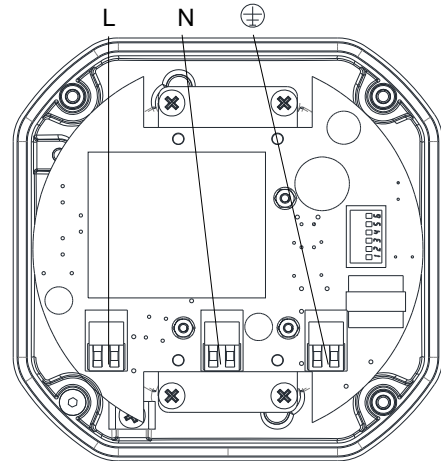

Fig. 3 D2XB1LD2 AC Terminals

## 10) DC Wiring

3-off 2-way terminal blocks are provided on the AC beacon for power. There are 2-off +ve, 2-off -ve, 1-off Stage 2 and 1-off stage 3 terminals in total.

For further wiring schematics refer to document D211-06-401

### 10.1. PCBA Terminals

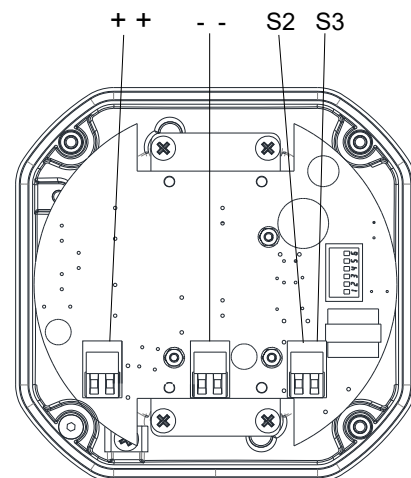

Fig. 4 D2XB1LD2 DC Terminals

### 10.2. Line Monitoring

On D2XB1LD2 DC units, DC reverse line monitoring can be used if required. All DC beacons have a blocking diode fitted in their supply input lines. An end of line monitoring resistor can be connected across the +ve and -ve terminals. If an end of line resistor is used it must have the following values:

	Min. Resistance	Min. Power
24V DC	3.9KΩ	0.5W
	1KΩ	2W
48V DC	15KΩ	0.5W
	3.9KΩ	2W

The resistor must be connected directly across the +ve and -ve terminals as shown in the following drawing. Form the resistor legs as shown in Fig. 5, remove the +ve and -ve terminal plugs and fit the resistor across the two terminal plugs before refitting them to the PCBA as shown in Fig. 6. A spacing of at least 1/16" (1.58mm) must be provided through air and over surfaces between uninsulated live parts.

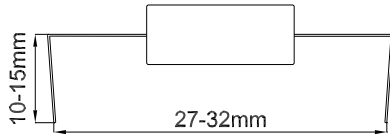

Fig. 5 End of Line Resistor Forming

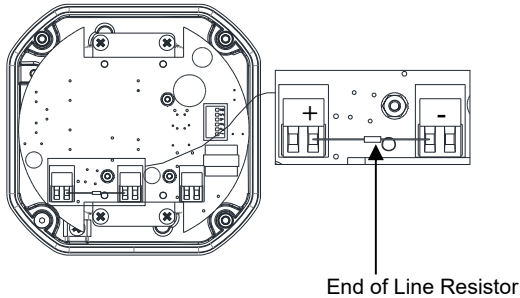

Fig. 6 End of Line Resistor Placement

## 11) Earthing

The unit has both internal and external earth terminals, (please see fig 3).

Internal earthing connections should be made to the internal earth terminal on the PCBA, (please see fig 3 for AC, fig 4 for DC). The earth conductor should be at least equal in size and rating to the incoming power conductors. The internal earth bonding wire connects the PCBA earth terminal to the internal earth terminal in the enclosure back box.

External earth connections should be made to the M5 earth stud, using a ring crimp terminal to secure the earth conductor to the earth stud. The external earth conductor should be at least 4mm<sup>2</sup> in size. The external earth crimp ring should be located between the two M5 plain washers provided and securely locked down with the M5 spring washer and M5 nut.

## 12) Settings

### 12.1. Flash Rate Setting



Warning – high-intensity light source. Avoid looking directly at the light source for extended periods of time.

The D2xB1LD2 beacons can produce different flash patterns as shown in Table 1. The flash patterns are selected by operation of the flash setting DIP switch on the PCB, Fig 6.

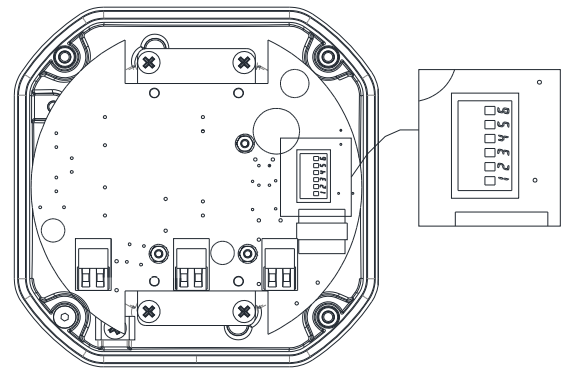

Fig. 7: DIP Switch Location

Switch Setting	S1 Mode	S2 Mode	S3 Mode
(123456)	(DC & AC)	(DC Only)	(DC Only)
000000	Steady High Power	Flashing 1Hz*	Flashing Triple Strike
000001	Steady Low Power	Flashing 1Hz*	Flashing Triple Strike
100000	Flashing 1Hz*	Flashing Double Strike	Flashing Triple Strike
101000	Flashing 1.33Hz*	Flashing 2Hz*	Flashing Double Strike
010000	Flashing 2Hz*	Flashing Triple Strike	Flashing Triple Strike
110000	Flashing Double Strike	Steady High Power	Flashing Triple Strike
001000	Flashing Triple Strike	Flashing 2Hz*	Flashing Double Strike

(\*setting permitted for use as public mode fire alarm device)

Table 1: Switch Positions for Flash Patterns



Fig. 8 Dip Switch

1=ON; 0=OFF

Example shown: 100000 = Flashing 1Hz (Default setting)

### 13) Interchangeable & Spare Parts (General Signaling and Private Mode Alarm Versions only)



Warning – Hot surfaces. External surfaces and internal components may be hot after operation, take care when handling the equipment.

The Beacon lens cover is interchangeable, contact E2S Ltd for a replacement lens cover available in various colours. Please note that Private Mode Fire Alarm units can only be used with either clear or red lenses, Public Mode Fire Alarm units cannot be used with a lens or a guard.

To change the lens cover, unscrew the 4-off M5 posi pan head screws, spring and flat washers using a screwdriver. Remove the wire guard and replace the old lens cover with the new lens cover.

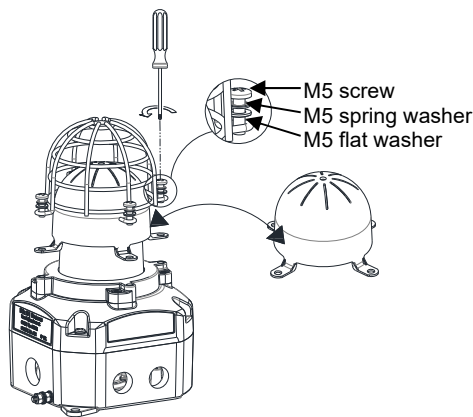

Fig. 9 Replacement of beacon lens cover

Fit the wire guard back onto the housing, over the new lens cover aligning the fixing holes of the guard, lens cover and housing. Refit the fixings to hold into place, the fixings MUST be fitted in the order shown above.

### 14) Maintenance, Overhaul & Repair

Maintenance, repair and overhaul of the equipment should only be carried out by suitably qualified personnel in accordance with the current relevant standards:

- EN60079-19 Explosive atmospheres - Equipment repair, overhaul and reclamation
- IEC60079-19
- EN 60079-17 Explosive atmospheres - Electrical installations inspection and maintenance
- IEC60079-17

To avoid a possible ELECTROSTATIC CHARGE the unit must only be cleaned with a damp cloth.

Units must not be opened while an explosive atmosphere is present.

If opening the unit during maintenance operations a clean environment must be maintained and any dust layer removed prior to opening the unit.

## 15) Electrical Ratings

### 15.1 Operating current Consumption

Table 6 – Electrical Ratings					
Model	Nom. Voltage	Voltage Range	Flash Rate Setting	Nom. operating current <sup>#</sup>	Max. operating current <sup>##</sup>
D2xB1LD2DC024 (D2xB1LD2-H)	24Vdc	Regulated 24 (16-33Vdc)*	1Hz (60fpm)	99.5mA	273mA
			1.33Hz (80 fpm)	104mA	275mA
			2Hz (120fpm)	103mA	240mA
D2xB1LD2DC024	24Vdc	18-54Vdc**	Steady High Power	242mA	346mA
			Steady Low Power	128mA	184mA
			Flashing 1Hz	99.5mA	147mA
			Flashing 1.33Hz	104mA	143mA
			Flashing 2Hz	103mA	146mA
			Flashing Double Strike	122.4mA	180mA
			Flashing Triple Strike	144.8mA	211.2mA
D2xB1LD2AC115	115Vac 60Hz	115-120Vac 50/60Hz	Steady High Power	83mA	102.4mA
			Steady Low Power	53mA	88.1mA
			Flashing 1Hz	68mA	99.7mA
			Flashing 1.33Hz	64.1mA	97.6mA
			Flashing 2Hz	59.2mA	93.8mA
			Flashing Double Strike	68.3mA	99.9mA
			Flashing Triple Strike	72.8mA	102.3mA
D2xB1LD2AC230	230Vac 50Hz	220-230Vac 50/60Hz	Steady High Power	52mA	52mA
			Steady Low Power	42mA	42mA
			Flashing 1Hz	70mA	75mA
			Flashing 1.33Hz	61mA	75mA
			Flashing 2Hz	51mA	62mA
			Flashing Double Strike	71mA	71mA
			Flashing Triple Strike	66mA	69mA

\* For Public Mode Fire Alarm use

\*\* For private mode Fire Alarm or General Signalling use

# nominal rms current at nominal voltage

## max. rms current at worst-case voltage in voltage range.

OPTIONAL LINE MONITORING RESISTOR, CUSTOMER SUPPLIED,  
RECOMMENDED MINIMUM VALUES:  
24VDC : 1KΩ MIN, 2W MIN OR 3K9Ω MIN, 0.5W MIN  
48VDC : 3.9KΩ MIN, 2W MIN OR 15KΩ MIN, 0.5W MIN

ISSUE	MOD No.	REASON - INITIAL - DATE
1		INTRODUCTION RSR 28-11-2019
2		UPDATED FORMAT DH 17-05-2022

DC LED D2XB1LD2 UNITS

Line Monitoring  
 Stage 1 Flash Pattern: Apply power to +ve & -ve  
 Stage 2 Flash Pattern: Apply power to +ve & -ve. Connect Stage 2 to -ve  
 Stage 3 Flash Pattern: Apply power to +ve & -ve. Connect Stage 3 to -ve

AC LED D2XB1LD2 UNITS

Power: Live & Neutral

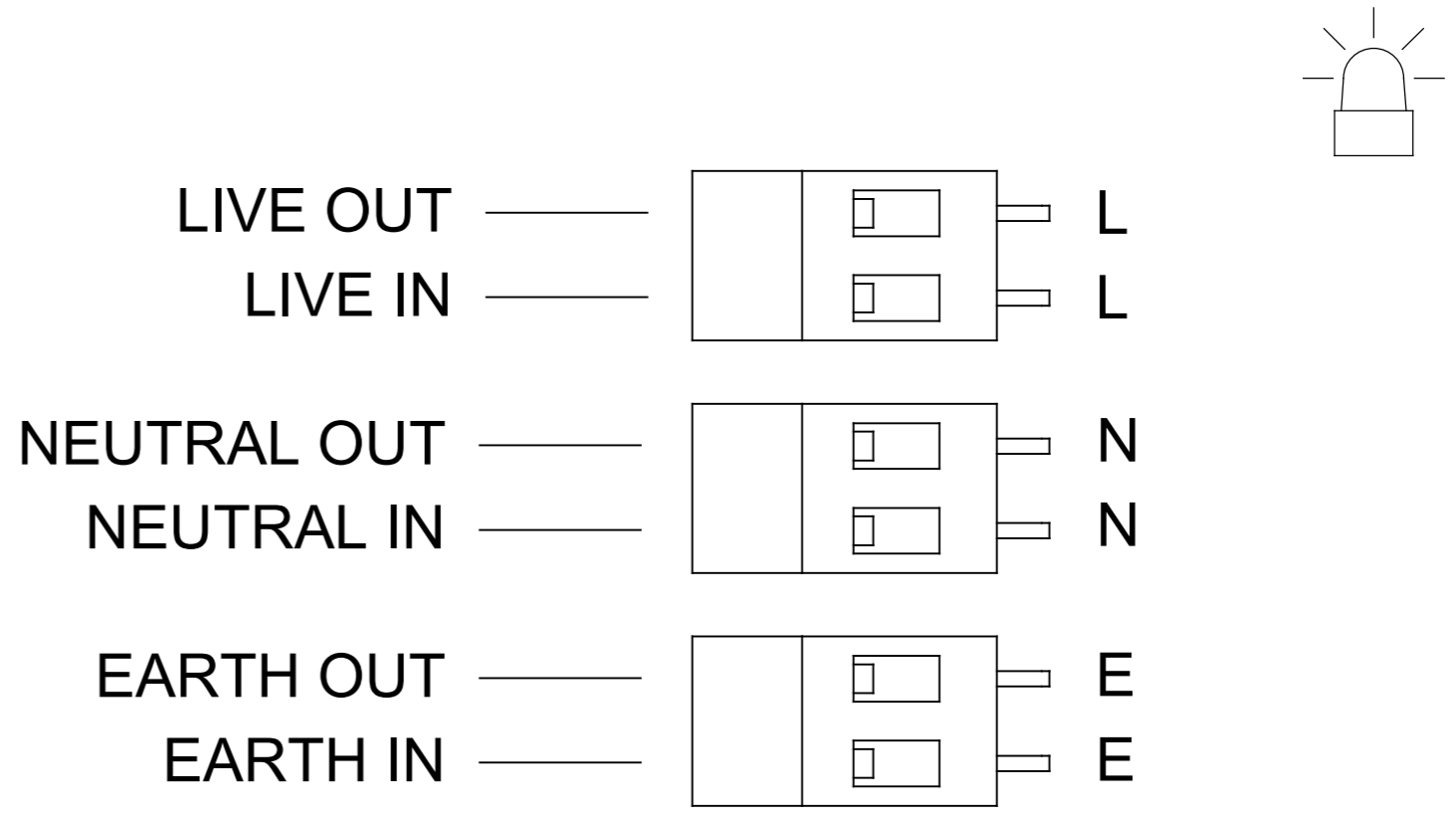
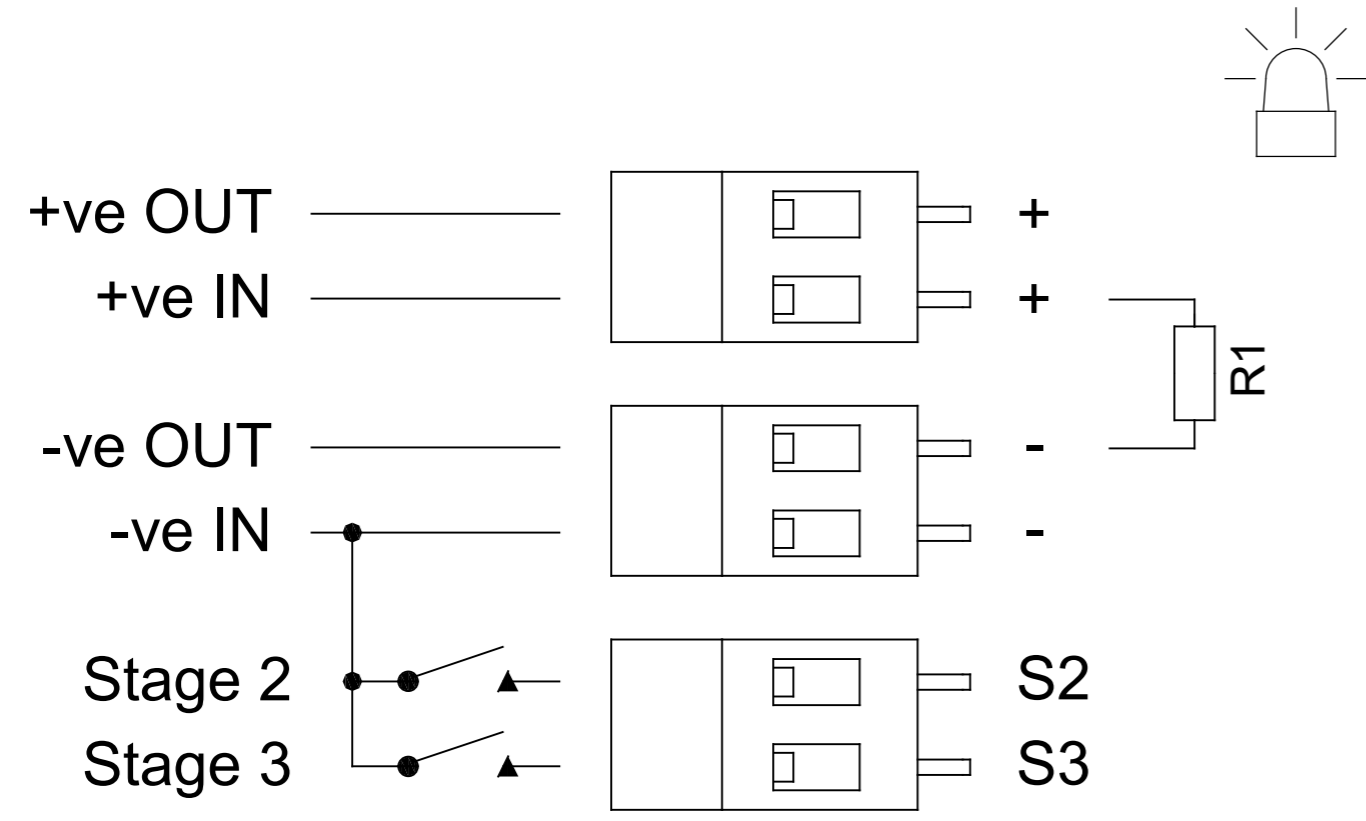

DRAWING TO BS8888:2000  
 GEOMETRIC TOLERANCES TO ISO1101:1983  
 LINEAR DIMENSIONAL TOLS +/-0.35mm  
 ANGULAR DIMENSIONAL TOLS +/-2 deg  
 STANDARDS  
 GNEXCP7PT UL 38

DRAWN	DATE
R.S. RAIT	27-06-2019
CHECKED	DATE
B. ISARD	27-06-2019
APPROVED	DATE
R.N.POTTS	27-06-2019

SURFACE FINISH	WEIGHT (Kg)
MATERIAL	
ALTERNATIVE MATERIAL	

THIS DRAWING AND ANY INFORMATION OR DESCRIPTIVE MATTER THEREIN IS COMMUNICATED IN CONFIDENCE AND IS THE COPYRIGHT PROPERTY OF EUROPEAN SAFETY SYSTEMS LTD. NEITHER THE WHOLE OR ANY EXTRACT MAY BE DISCLOSED, LOANED, COPIED OR USED FOR MANUFACTURING OR TENDERING PURPOSES WITHOUT THEIR WRITTEN CONSENT.  
 © EUROPEAN SAFETY SYSTEMS LTD.  
 AS PER LATEST DATE OF ISSUE SHOWN ABOVE

**e2s** warning signals  
 EUROPEAN SAFETY SYSTEMS LTD  
 IMPRESS HOUSE  
 MANSELL ROAD  
 ACTON  
 LONDON W3 7QH  
 WWW.E2S.COM

ALL DIMENSIONS IN MM IF IN DOUBT, ASK - DO NOT SCALE			A3
TITLE D2xB1LD2 BEACONS WIRING DIAGRAM			
SCALE NTS	SHEET 1 OF 1	DRAWING NUMBER D211-06-401	

# EU Declaration of Conformity



Manufacturer: European Safety Systems Ltd.  
Impress House, Mansell Road, Acton  
London, W3 7QH  
United Kingdom

Authorised Representative: E2S Warnsignaltechnik UG  
Charlottenstrasse 45-51  
72764 Reutlingen  
Germany

Equipment Type: D2xS1, D2xS2, D2xL1, D2xL2, D2xC1X05, D2xC1X10  
D2xB1X05, D2xB1X10, D2xB1LD2, D2xB1XH1, D2xB1XH2, D2xB1LD3  
D2xC2X05, D2xC2X10, D2xC2LD2, D2xC2XH1, D2xC2XH2, D2xC2LD3  
D2xJ1

---

## Directive 2014/34/EU: Equipment and Protective Systems for use in Potentially Explosive Atmospheres (ATEX)

Notified Body for EU type Examination (Module B):	UL International Demko A/S Notified Body No.: 0539 Borupvang 5A, 2750 Ballerup, Denmark
EU-type Examination Certificate (Module B):	DEMKO 14 ATEX 4786493904X
Notified Body for Quality Assurance Notification / Conformity to EU-type based on quality assurance of the production process (Module D):	Sira Certification Service Notified Body No.: 2813 CSA Group Netherlands B.V, Utrechtseweg 310, 6812 AR, Arnhem, Netherlands
Quality Assurance Notification (Module D):	SIRA 05 ATEX M342
Provisions fulfilled by the equipment:	II 3G Ex ec IIC T6/T5/T4A/T4/T3C/T3/T2/T1 Gc II 3D Ex tc IIIC T55/75/80/85/90/93/95/105/109/110/119°C Dc Ingress / Dust Protection to EN60079-0 / EN60079-31: IP66
Standards applied:	EN IEC 60079-0:2018 EN IEC 60079-7:2015 +A1:2018 EN 60079-31:2014

## Directive 2014/30/EU: Electromagnetic Compatibility Directive (EMC)

Standards applied:	EN 61000-6-1:2007 EN 61000-6-2:2005 EN 61000-6-3:2007 / A1:2011 / AC: 2012 EN 61000-6-4:2007 / A1: 2011
--------------------	--

## Directive 2011/65/EU: Restriction of the use of certain hazardous substances in electrical and electronic equipment (RoHS)

The product and all the components contained within it are in accordance with the restriction of the use of hazardous substances in electrical and electronic equipment, including amendment by Directive 2015/863/EU.

# EU Declaration of Conformity



Regulation (EC) 1907/2006: Registration, Evaluation, Authorisation and Restriction of Chemicals (REACH)

The product and all the components contained within it are free from substances of very high concern.

Other Standards and Regulations

EN 60529:1992+A2:2013 - Degrees of protection provided by enclosures (IP code) – enclosure rated:

IP66 All units

IP66/67 D2xL1, D2xL2, D2xS2 only

---

On behalf of European Safety Systems Ltd., I declare that, on the date the equipment accompanied by this declaration is placed on the market, the equipment conforms with all technical and regulatory requirements of the above listed directives, regulations and standards.

This Declaration is issued under the sole responsibility of the manufacturer.

A handwritten signature in black ink, appearing to read 'Martin Streetz', written over a light blue circular stamp.

Martin Streetz  
Quality Assurance Manager

Document No.: DC-061\_Issue\_K  
Date and Place of Issue: London, 04/12/2023



# UKCA Declaration of Conformity



Manufacturer: European Safety Systems Ltd.  
Impress House, Mansell Road, Acton  
London, W3 7QH  
United Kingdom

Equipment Type: D2xS1, D2xS2, D2xL1, D2xL2, D2xC1X05, D2xC1X10  
D2xB1X05, D2xB1X10, D2xB1LD2, D2xB1XH1, D2xB1XH2, D2xB1LD3  
D2xC2X05, D2xC2X10, D2xC2LD2, D2xC2XH1, D2xC2XH2, D2xC2LD3  
D2xJ1

---

Directive UKSI 2016:1107 (as amended by UKSI 2019:696) – Schedule 3A, Part 1 : Product or Protective System Intended for use in Potentially Explosive Atmospheres (UKCA)

Notified Body for UK type Examination (Module B):	UL International (UK) Ltd Notified Body No.: 0843 Unit 1-3 Horizon Kingsland Business Park, Wade Road, Basingstoke, Hampshire RG24 8AH UK
UK-type Examination Certificate (Module B):	UL21UKEX2131X
Notified Body for Quality Assurance Notification / Conformity to EU-type based on quality assurance of the production process (Module D):	Sira Certification Service Notified Body No.: 0518 Rake Lane, Eccleston, Chester CH4 9JN, UK
Quality Assurance Notification (Module D):	CSAE 22UKQAN0046
Provisions fulfilled by the equipment:	II 3G Ex ec IIC T6/T5/T4A/T4/T3C/T3/T2/T1 Gc II 3D Ex tc IIIC T55/75/80/85/90/93/95/105/109/110/119°C Dc Ingress / Dust Protection to EN60079-0 / EN60079-31: IP66 All units
Standards applied:	EN IEC 60079-0:2018 EN IEC 60079-7:2015 +A1:2018 EN 60079-31:2014

Directive 2014/30/EU: Electromagnetic Compatibility Directive (EMC)

Standards applied:	EN 61000-6-1:2007 EN 61000-6-2:2005 EN 61000-6-3:2007 / A1:2011 / AC: 2012 EN 61000-6-4:2007 / A1: 2011
--------------------	--

Directive 2011/65/EU: Restriction of the use of certain hazardous substances in electrical and electronic equipment (RoHS)

The product and all the components contained within it are in accordance with the restriction of the use of hazardous substances in electrical and electronic equipment, including amendment by Directive 2015/863/EU.



# UKCA Declaration of Conformity



Regulation (EC) 1907/2006: Registration, Evaluation, Authorisation and Restriction of Chemicals (REACH)

The product and all the components contained within it are free from substances of very high concern.

Other Standards and Regulations

EN 60529:1992+A2:2013 - Degrees of protection provided by enclosures (IP code) – enclosure rated:

IP66 All units

IP66/67 D2xL1, D2xL2, D2xS2 only

---

On behalf of European Safety Systems Ltd., I declare that, on the date the equipment accompanied by this declaration is placed on the market, the equipment conforms with all technical and regulatory requirements of the above listed directives, regulations and standards.

This Declaration is issued under the sole responsibility of the manufacturer.

Martin Streetz  
Quality Assurance Manager

Document No.:  
Date and Place of Issue:

DC-102\_Issue\_B  
London, 04/12/2023